

18252-18

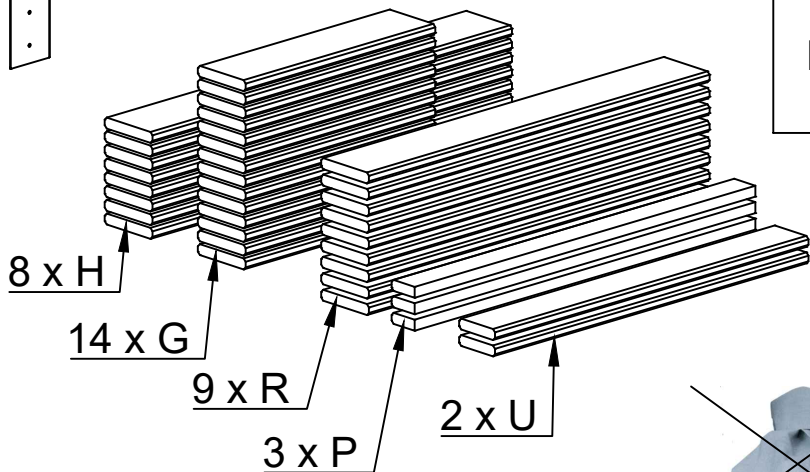

www.plus.dk

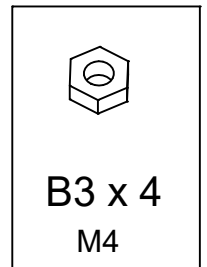
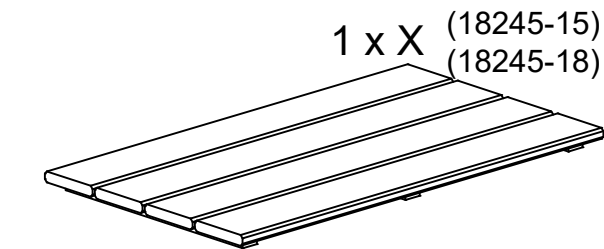
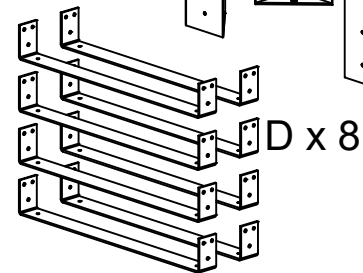
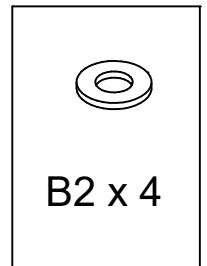
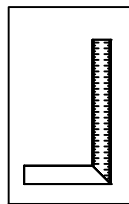
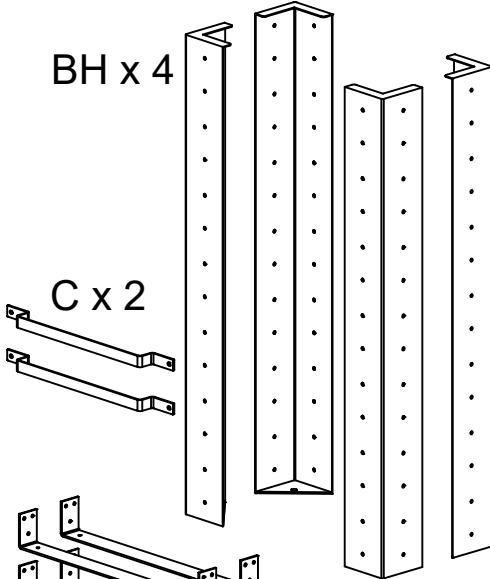
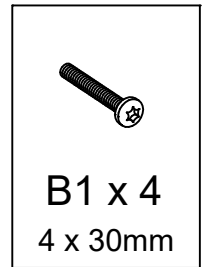
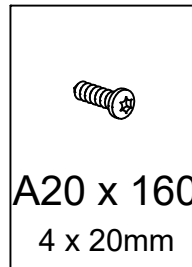
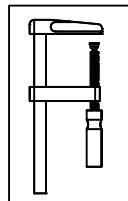
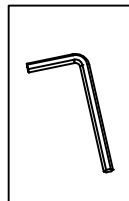
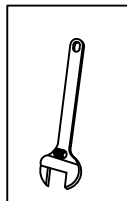
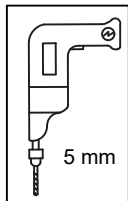
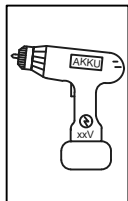
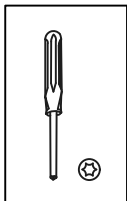
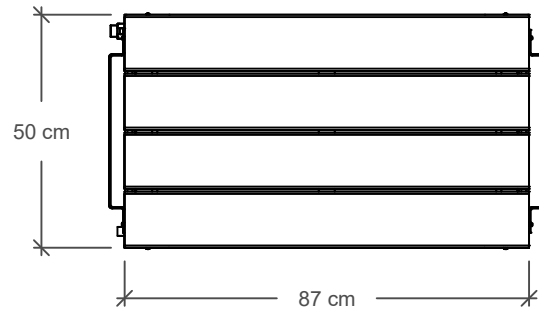
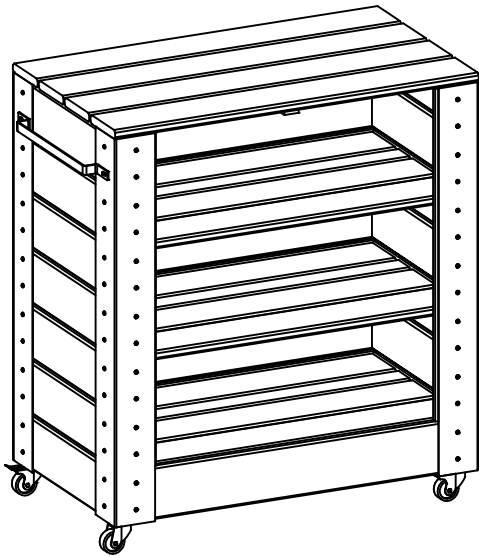

Revideret december 2015
Last update December 2015
Revidert desember 2015
Reviderad december 2015

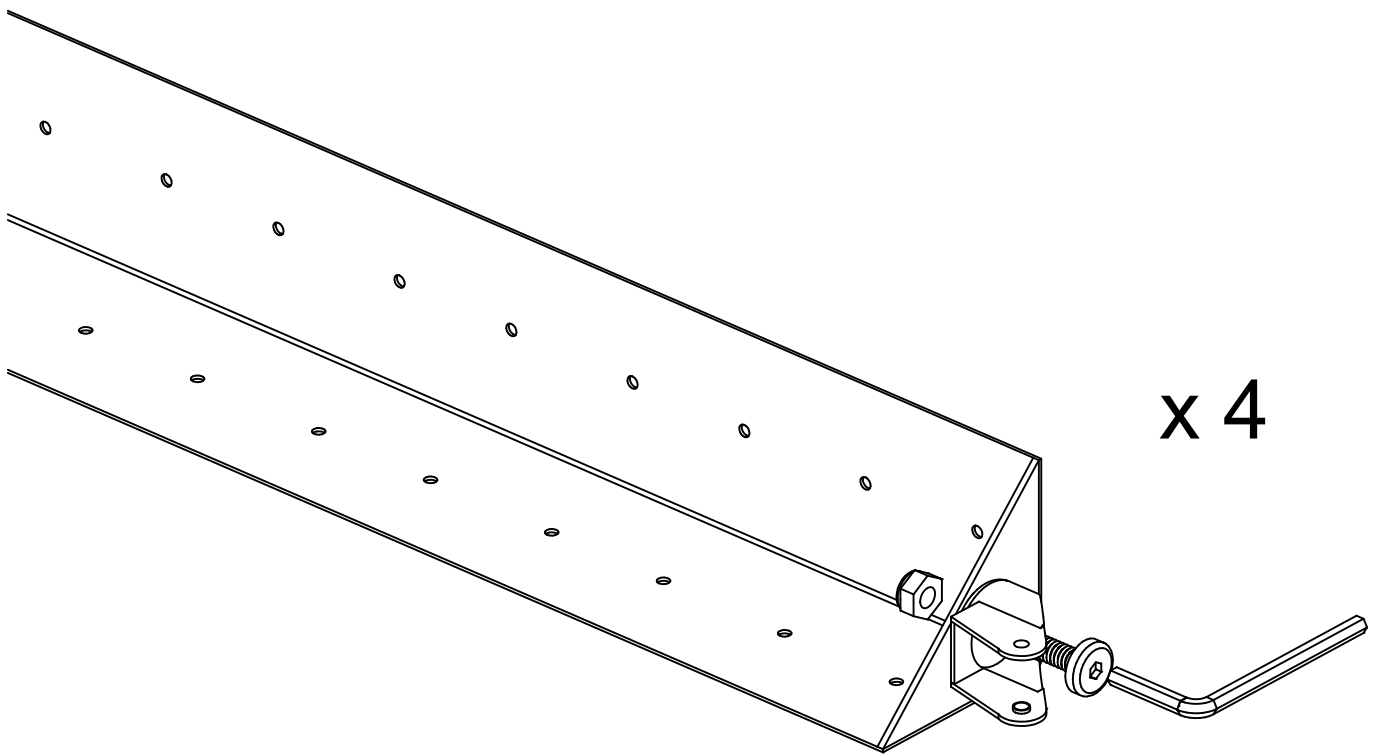
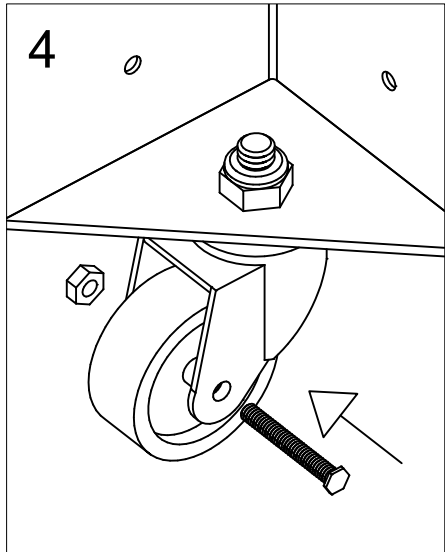
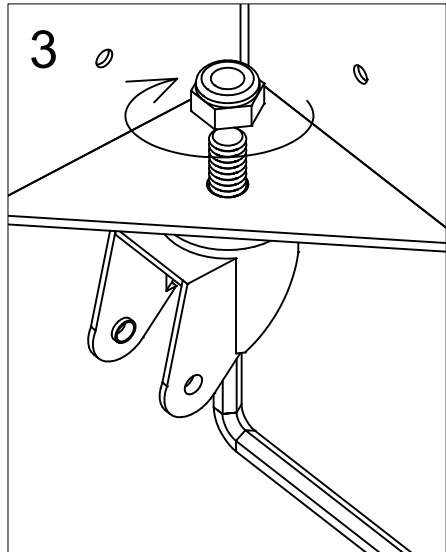
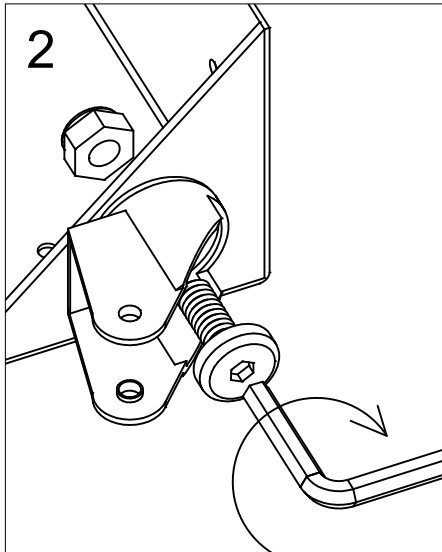
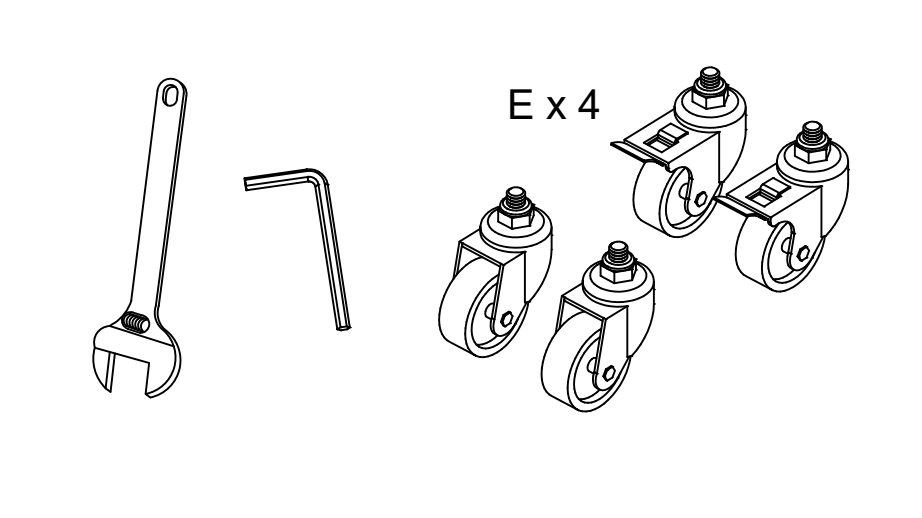
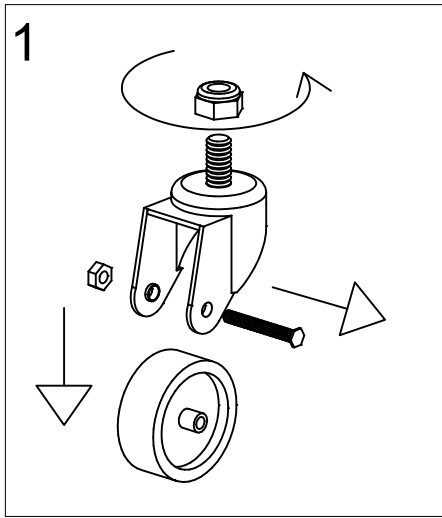

1. Øverste bræt, helt op til kanten.
Top board, right up to the edge.
Øverste Brett, helt opp til kanten.
Översta brädan, ända upp till kanten.
2. Nederste bræt, helt ned til kanten.
Bottom board, right down to the edge.
Nederste Brett, helt ned til kanten.
Nedersta brädan, ända ned till kanten.

Tips!

Brug f.eks. dette værktøj.
Use this tool.

Bruk f.eks. dette verktøyet.
Använd t.ex. detta verktyg.

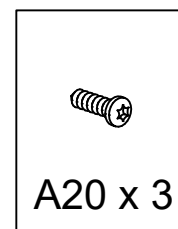
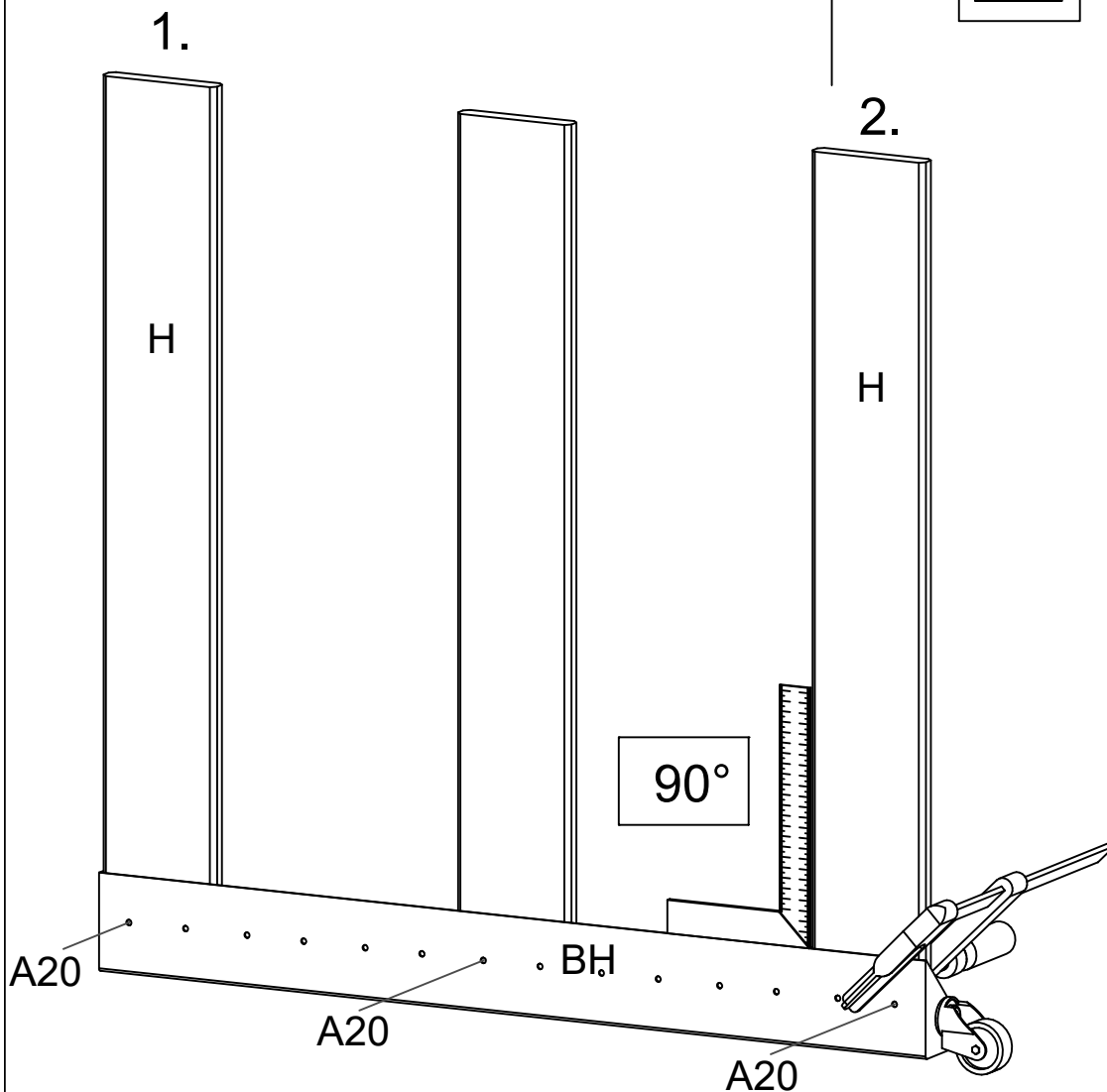
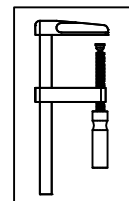
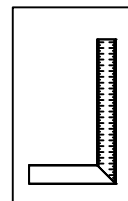

x 1

Tip !

Montere kun 1 skrue i hvert bræt, så der er mulighed for justering, når brættet skal fastgøres til det andet hjørne..!

Tips !

Mount only 1 screw in each board, so there is a possibility of adjustment when the board must be fixed to the other corner..!

Tips!

Fest kun én skrue i hvert Brett. Slik at du kan justere når brettet skal festes i det andre hjørnet!

Tips!

Montera bara en skruv i varje bräda. Så kan du justera när brädan ska fästas i det andra hörnet!

x 1

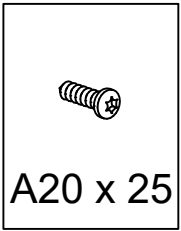
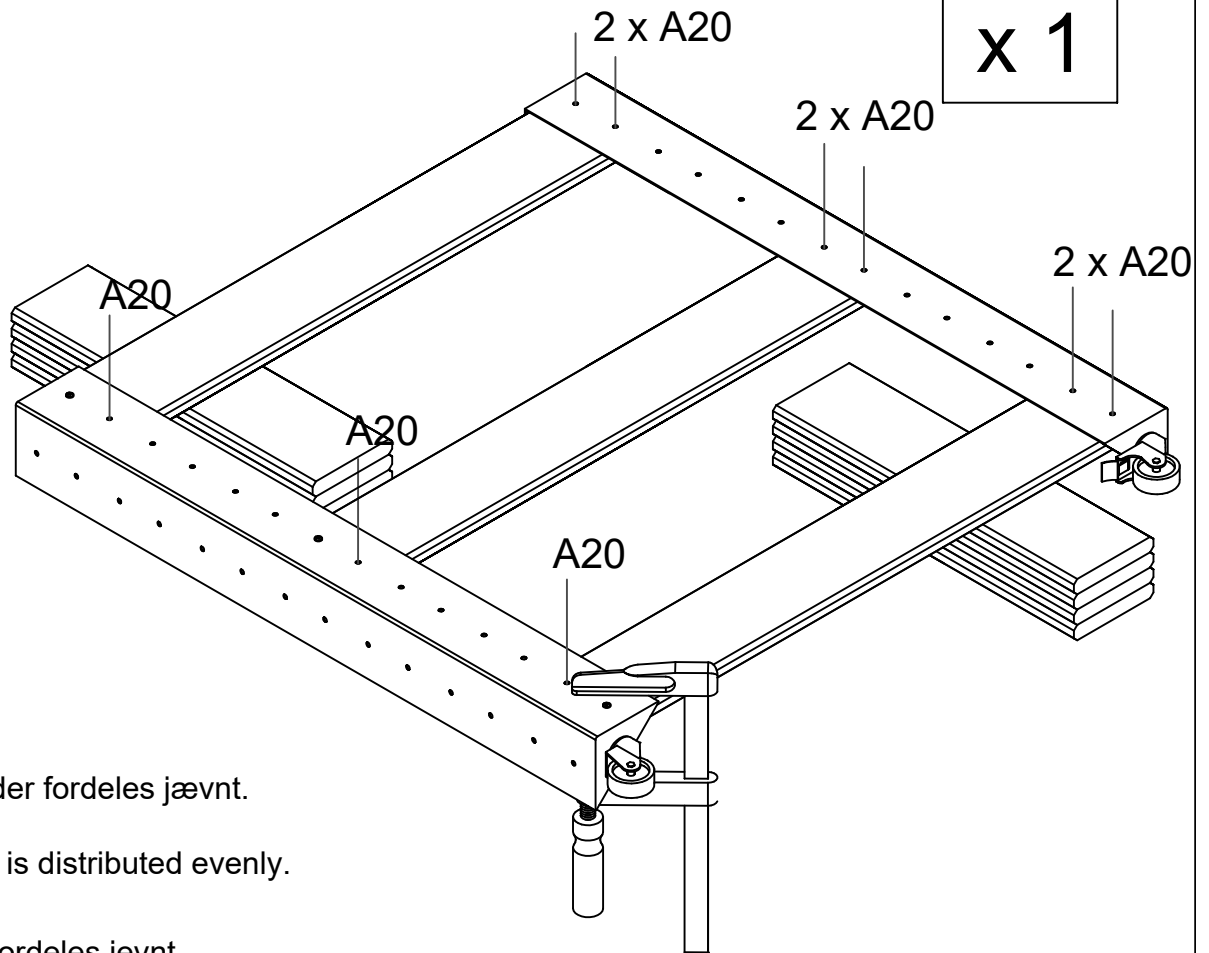

Øvrige brædder fordeles jævnt.

Other boards is distributed evenly.

Øvrige Brett fordeles jevnt.

Övriga brädor fördelas jämnt.

x 1

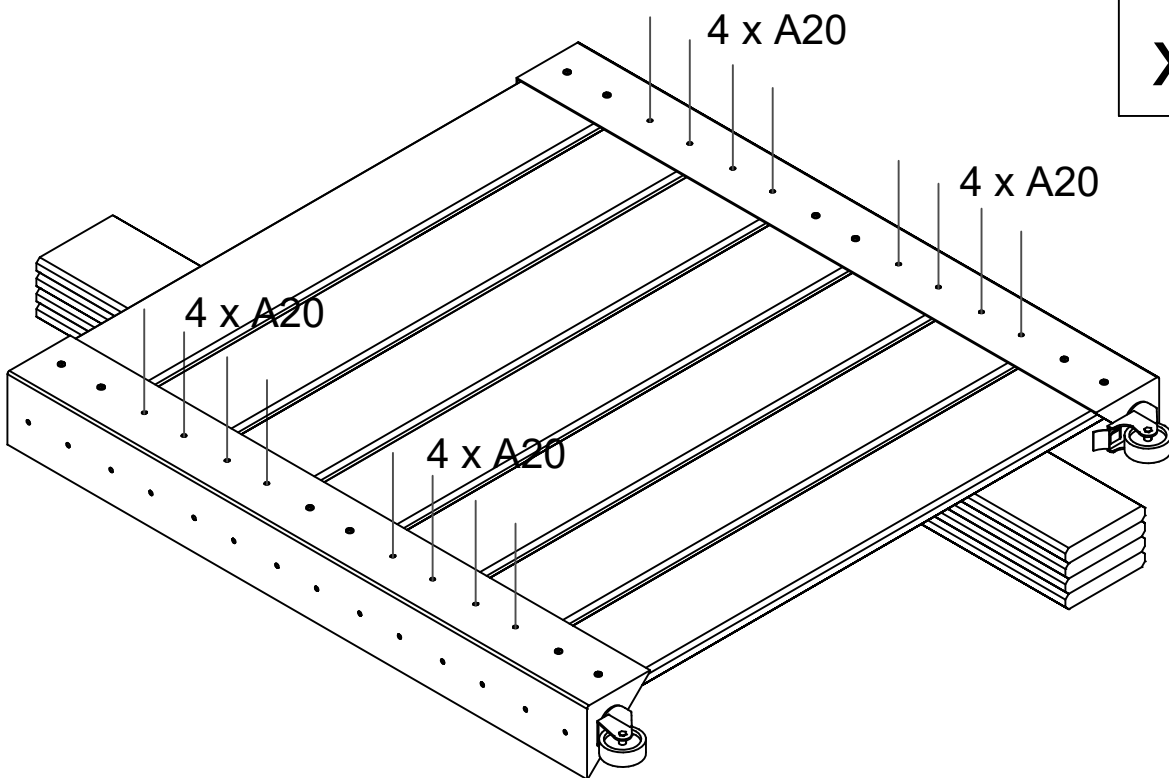

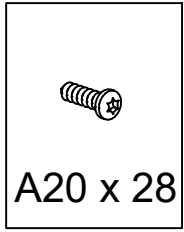

x 1

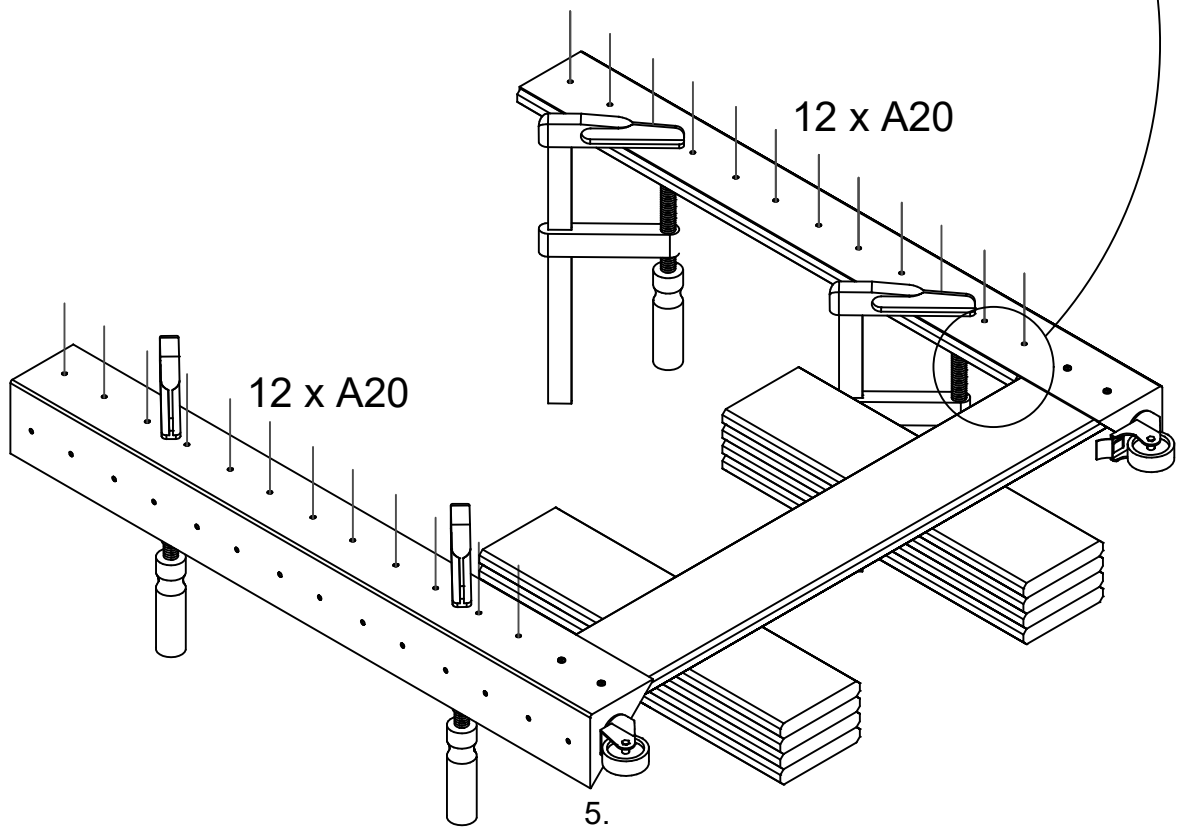
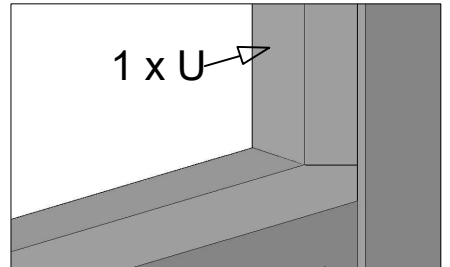
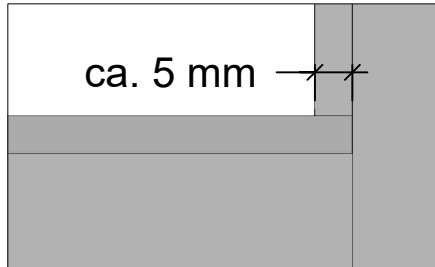
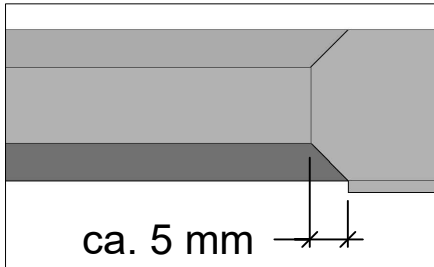
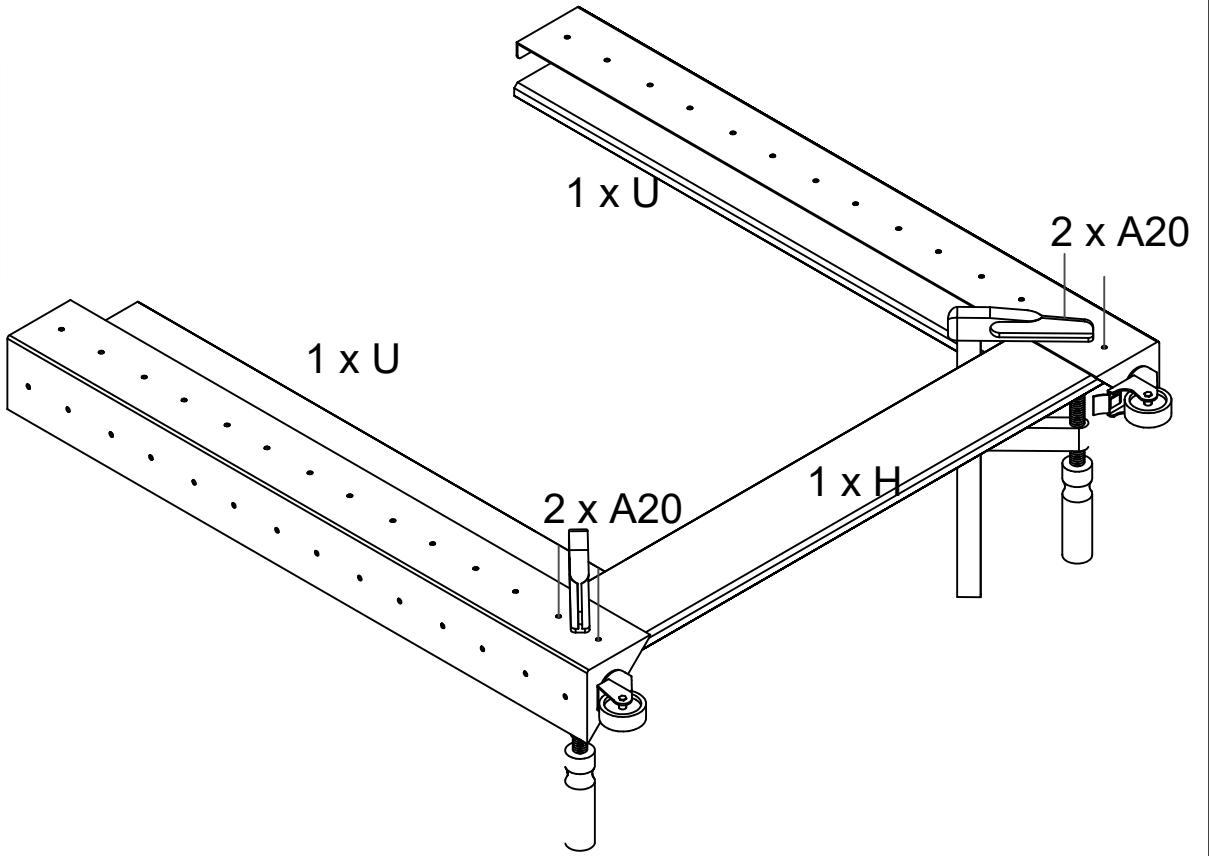

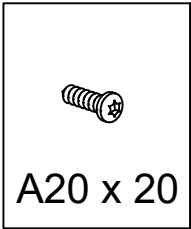

Side 1

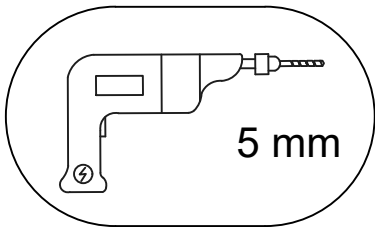
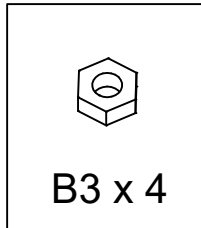
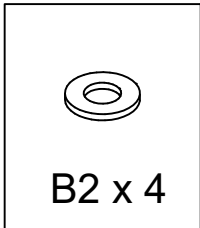
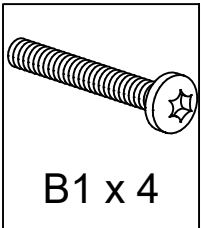
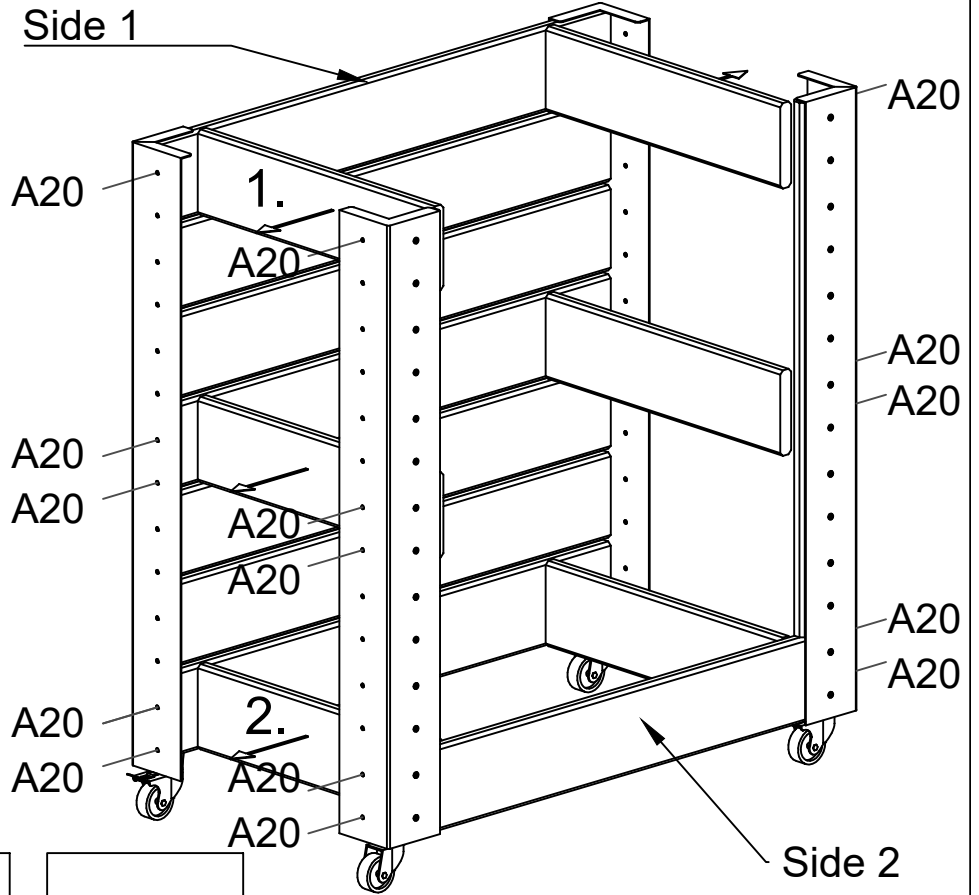

Forbores til bolt - 5 mm.
Pre-drill for bolt - 5 mm
Forbores til bolt - 5 mm.
Förborras för 5 mm bult.

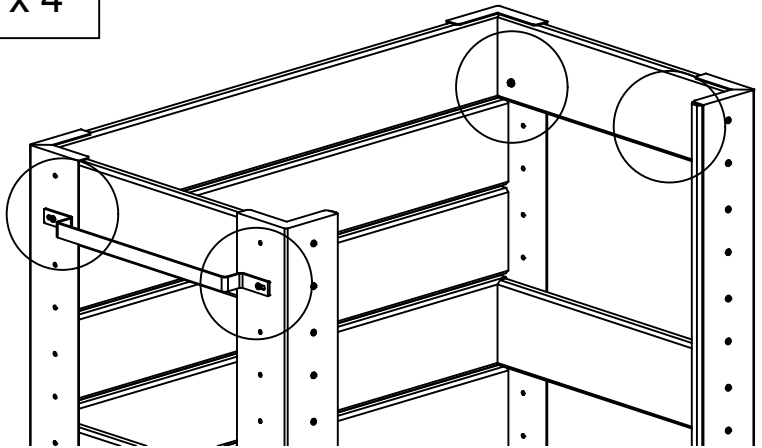

1)

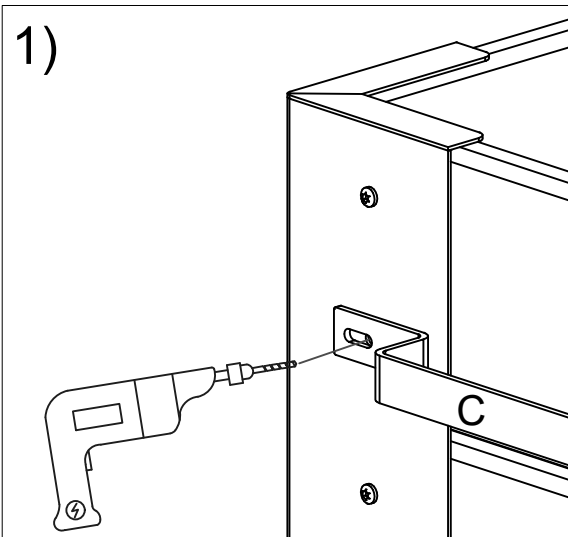

2)

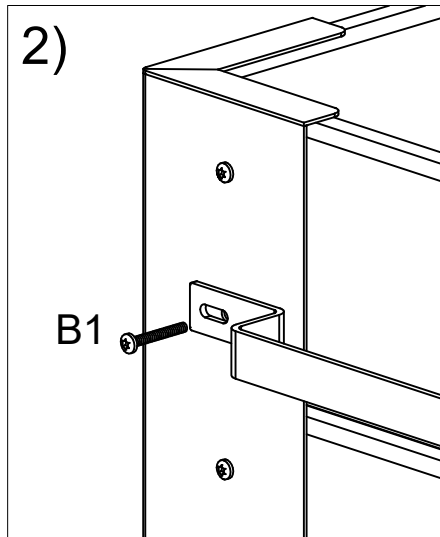

3)

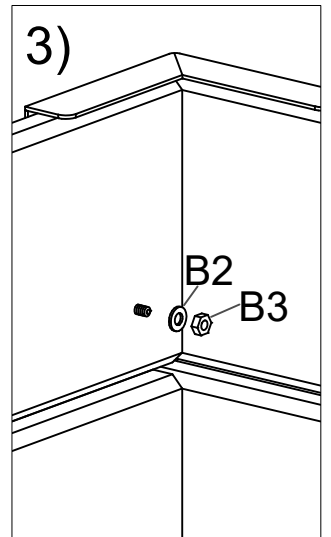

6.

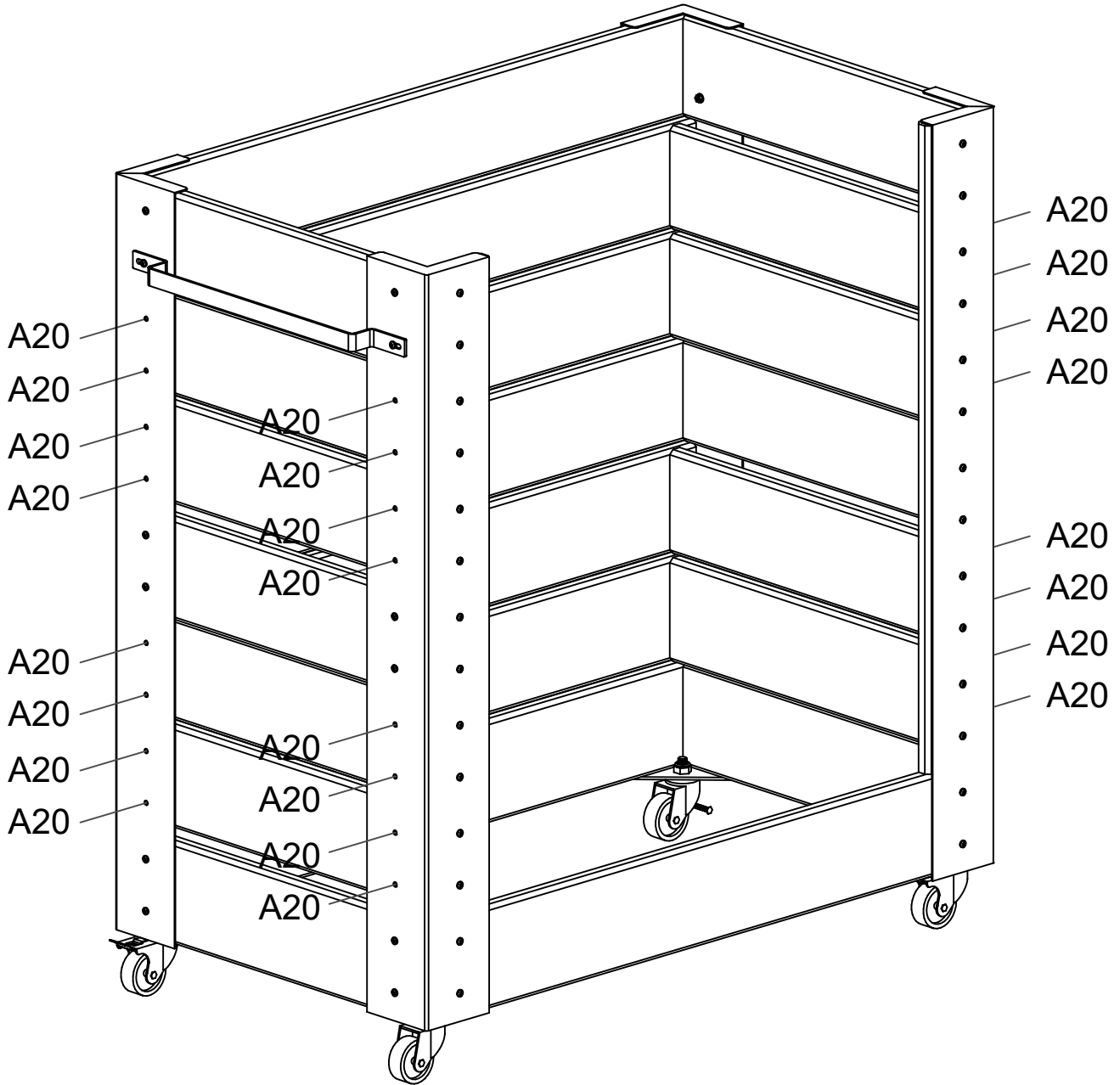
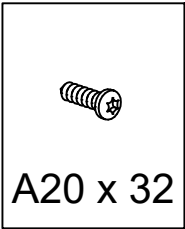

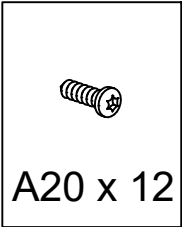

Placering af bundlister.
Bottom list position.
Placering av bunnlister.
Placering av bottenlister.

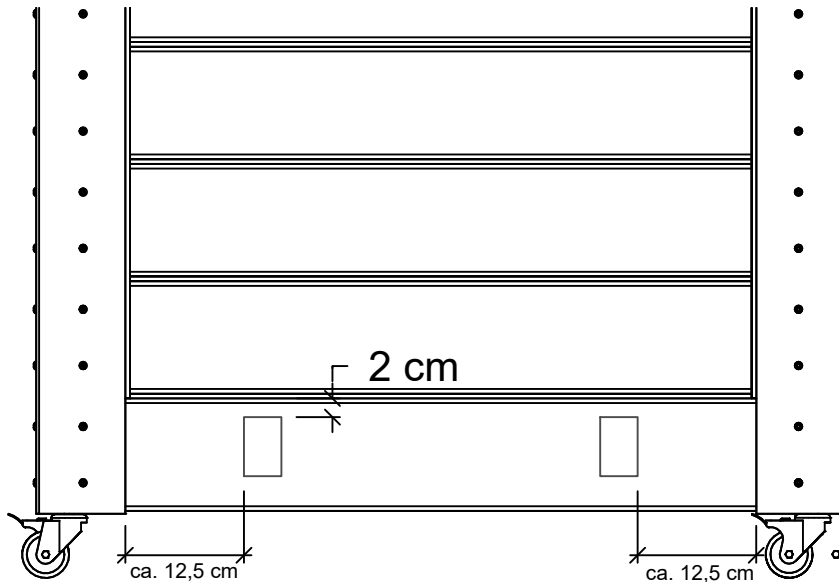
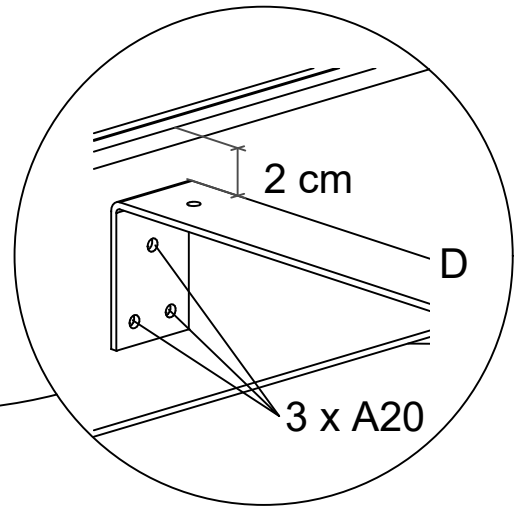
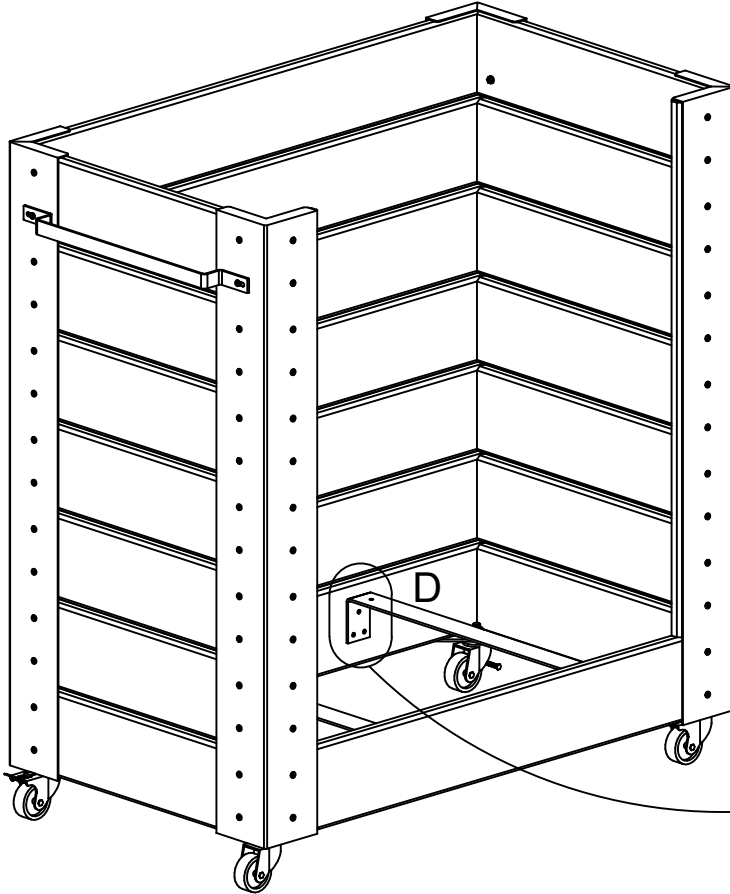
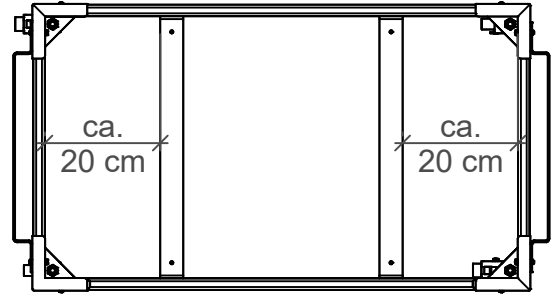
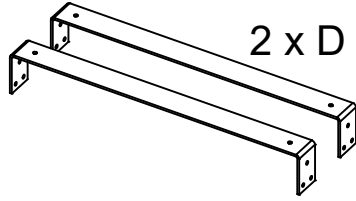

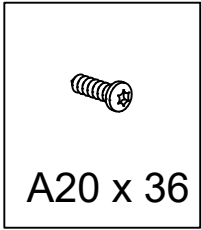

Placering af stållister
Placement of steel braces
Placering av stållister.
Placering av stållister.

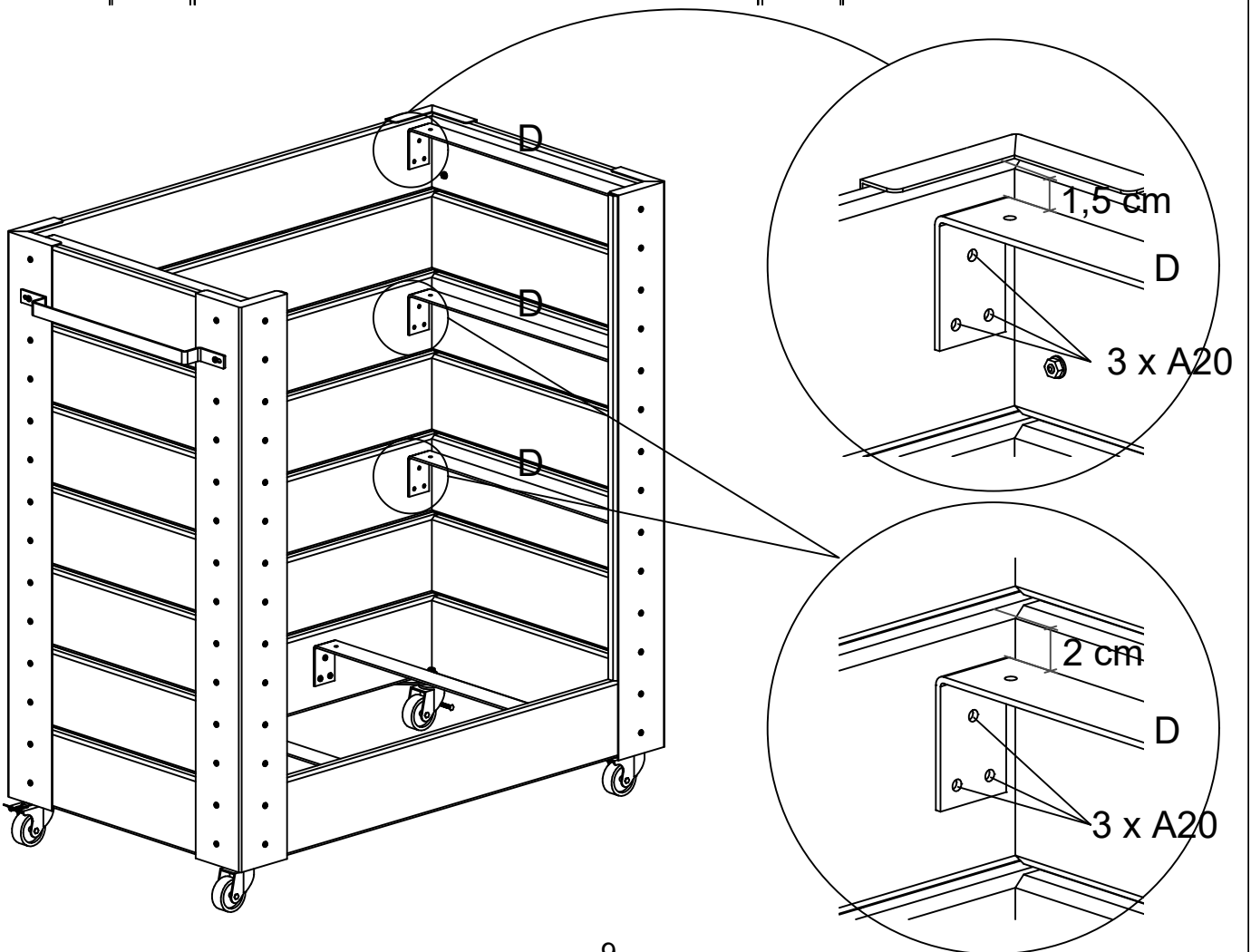
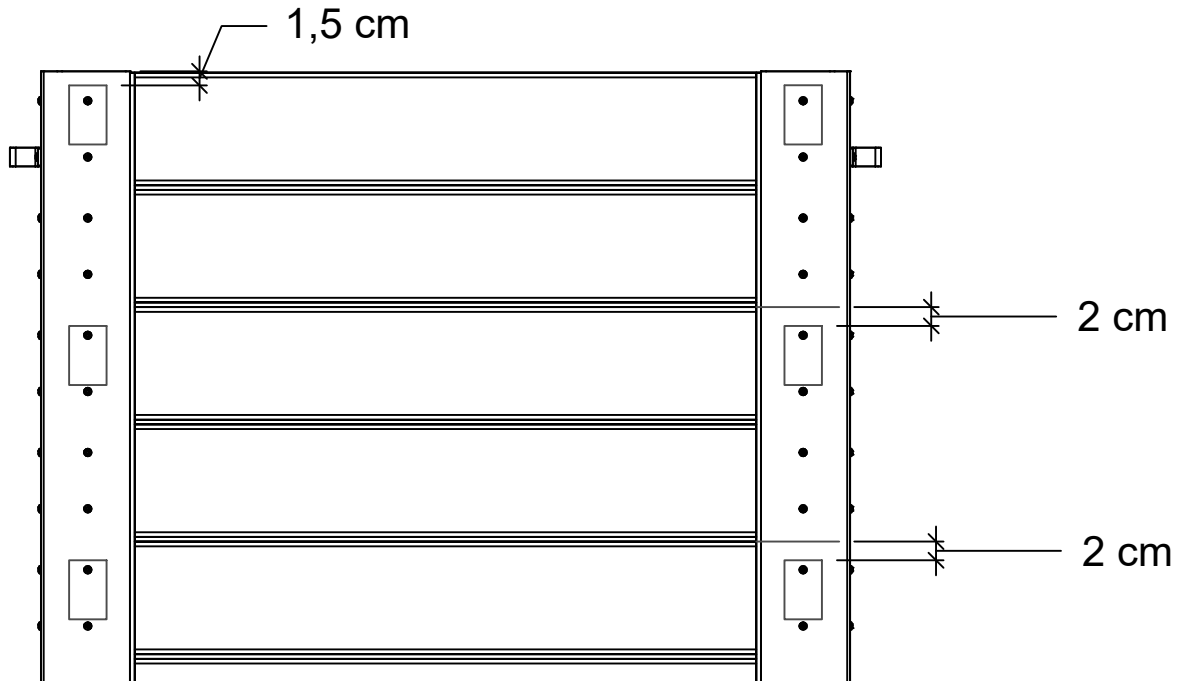
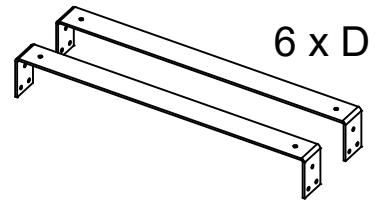

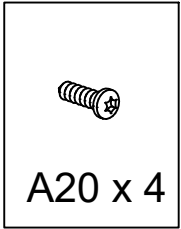

Fastgørelse af låg.
Attaching of the lid.
Festing av lokk.
Montering av lock.

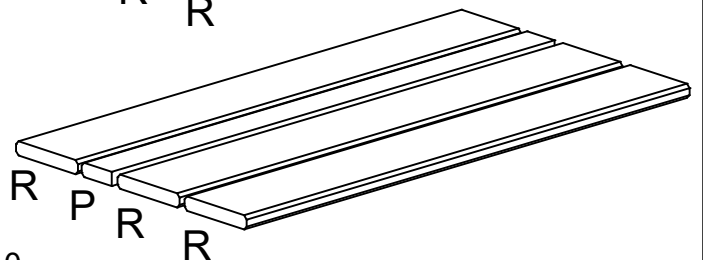
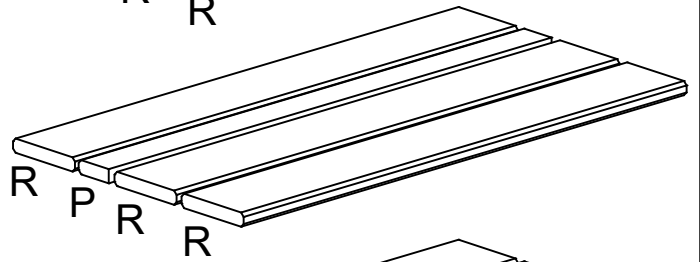
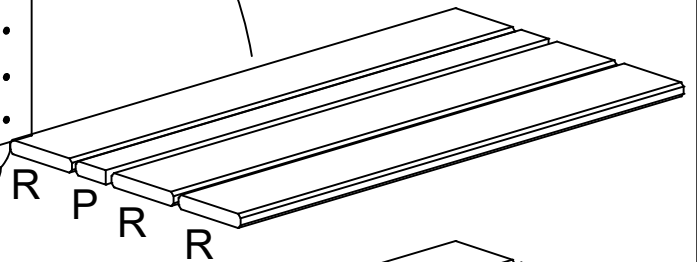
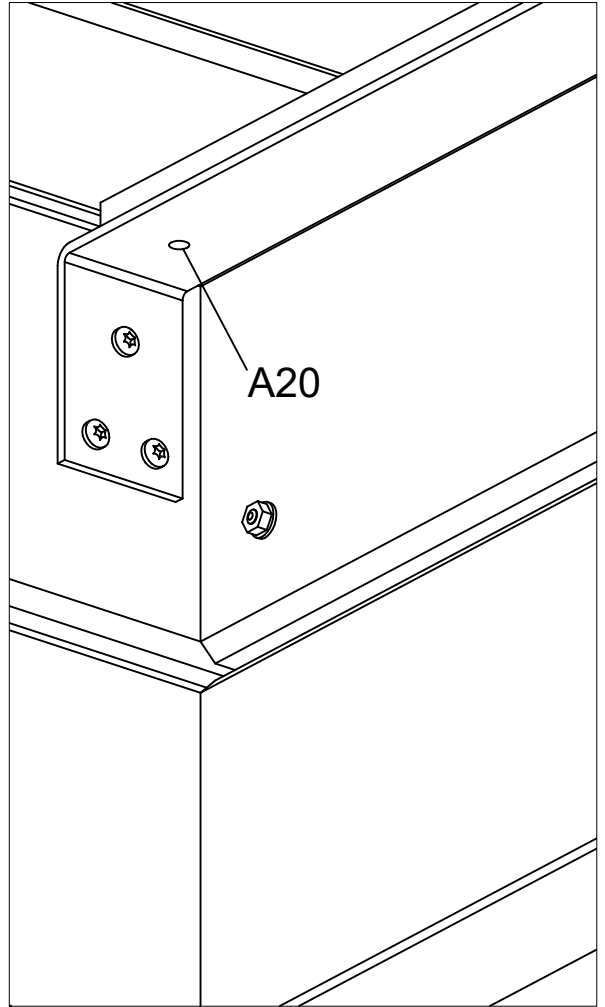
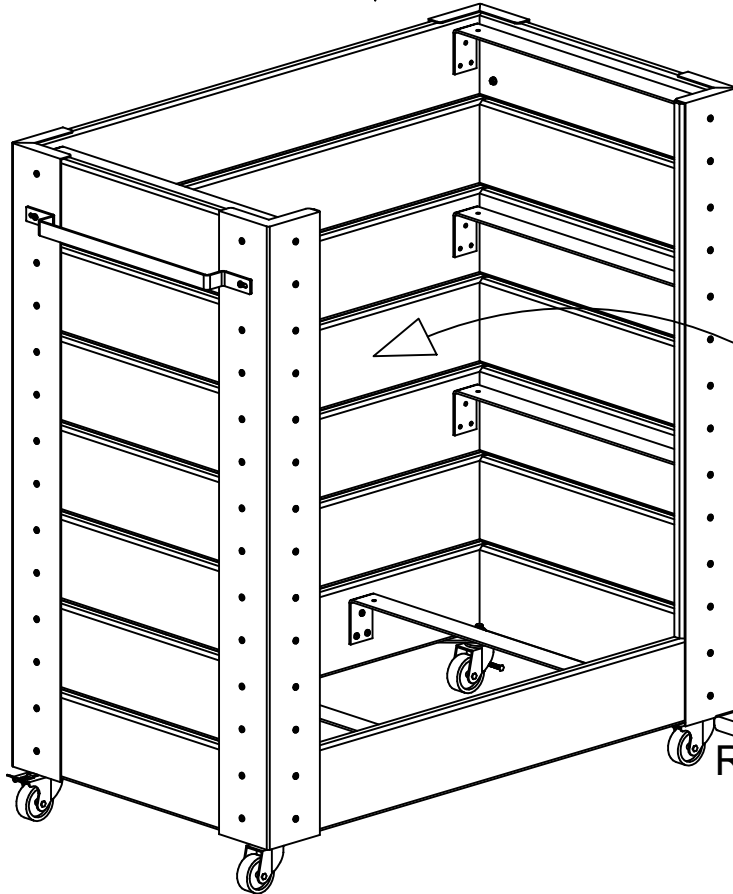
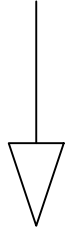
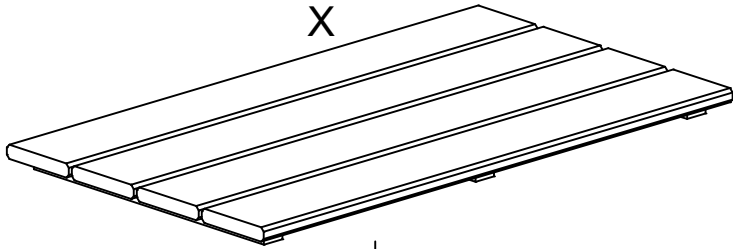

18252-18



www.plus.dk



Se www.plus.dk for yderligere information og vedligehold af materialer

www.plus.dk for further information and maintenance of materials

Se www.plus.dk for ytterligere informasjon og vedlikehold av materialer.

Se www.plus.dk för ytterligare information och underhåll av material.