

Stiltje



SVENSKA

Eftersom att omgivningen kan utgöras av många olika material, medföljer ej skruvar för infästning mot omgivningen. För råd om lämpliga skruvsystem kontakta din lokala fackhandel. Observera att Stilje partier alltid ska fixeras med omgivningen.

NORSK

Eftersom det finnes mange ulike typer av omgivelser, følger det ikke med skruer for montasje mot omgivelsen. Kontakt din lokale faghandel for råd om valg av skruer og festbeslag. Observere at Stilje partier alltid måtte fikseres med omgivelsen.

SUOMALAINEN

Koska ympäristö voidaan toteuttaa monesta eri materiaalista, ei kiinnitykseen tarvittavia ruuveja tule toimituksen mukana. Kysy neuvoa paikallisesta rautakaupasta sopivien ruuvien hankkimiseksi. Huomioi, että Stilje-elementit tulee aina tukea ympäristöön.”

ENGLISH

Since materials used in the surrounding environment varies, hardware for fastening to the surroundings are not included. For advice on suitable screw systems, contact your local specialized dealer. Stilje sections must always be secured to the surrounding environment.

DANSK

Eftersom det findes mange forskellige omgivelser, medfølger der ikke skruer til montring mod omgivelsen. For gode råd omkring skruesystemer, kontakt din lokale faghandel. Observere at Stilje sektioner altid måtte fikseres med omgivelsen.

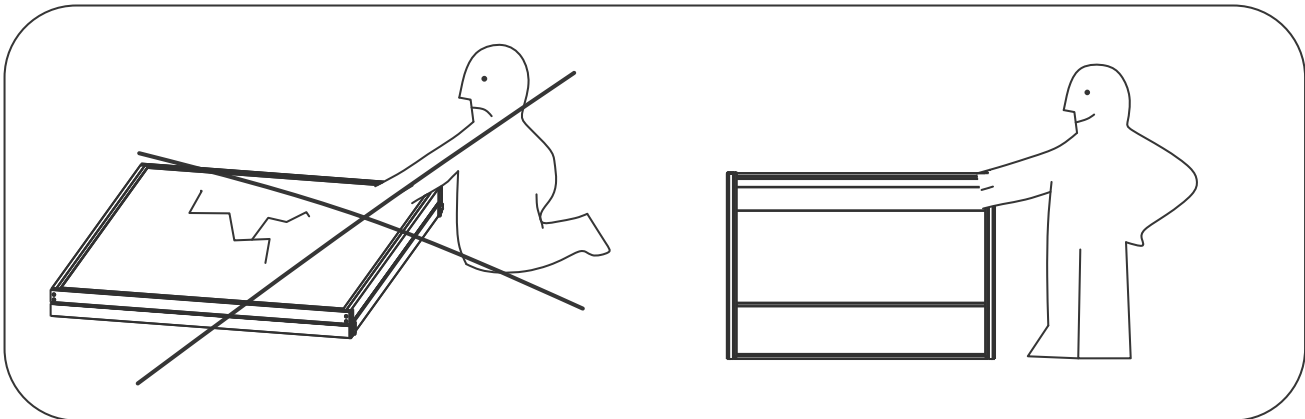
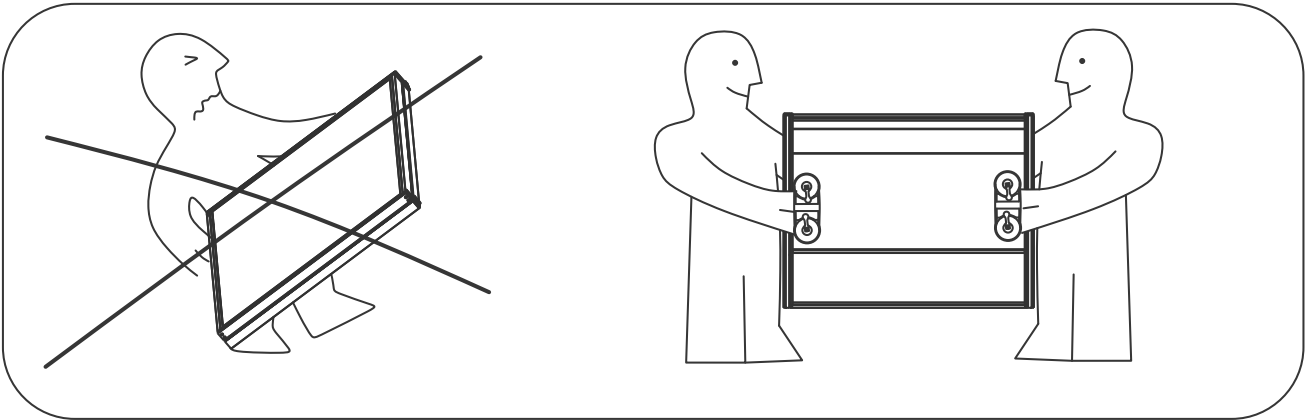
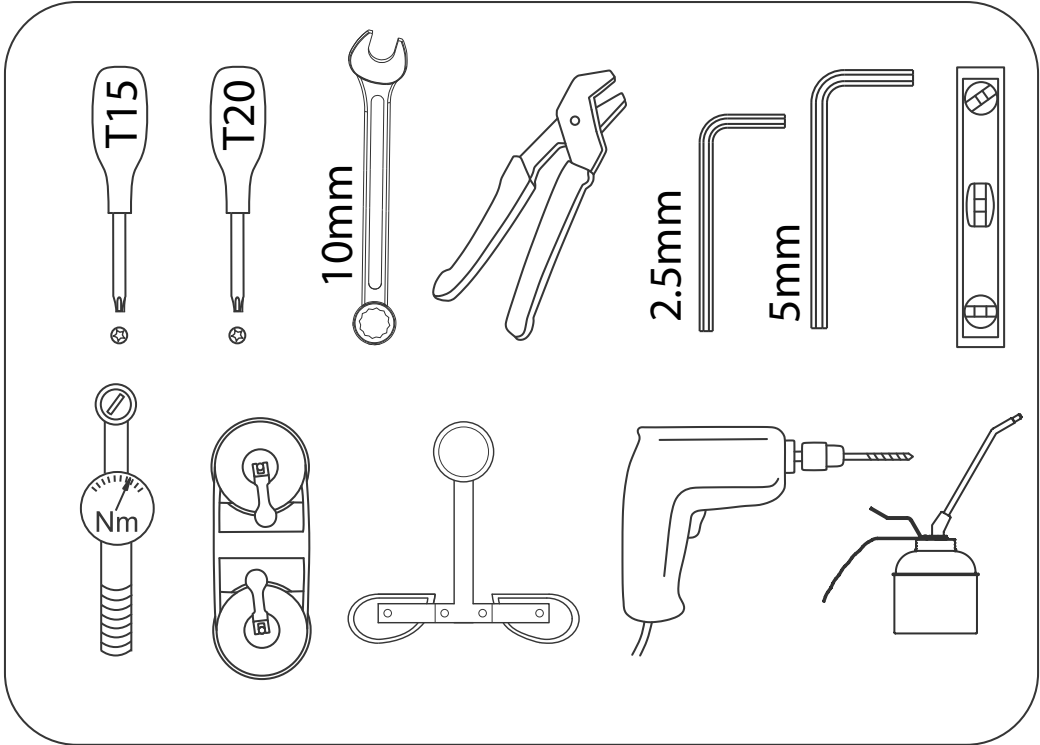
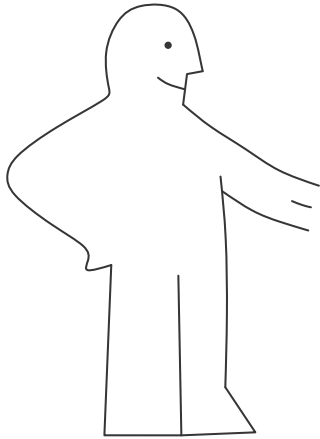

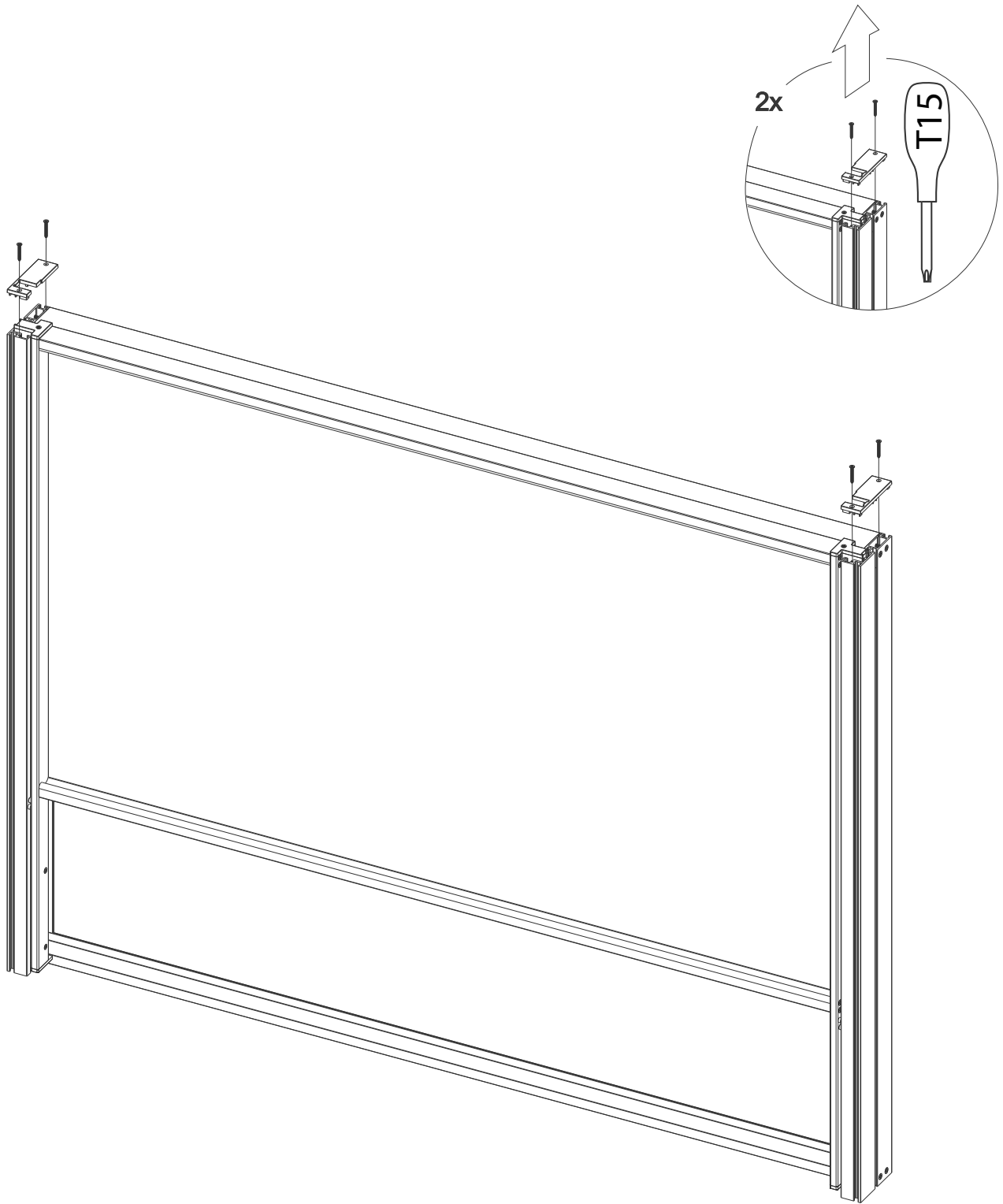

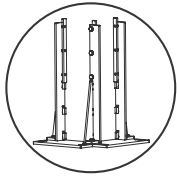
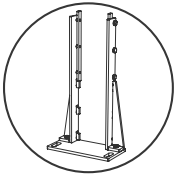

7

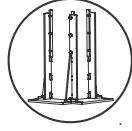

12

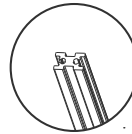
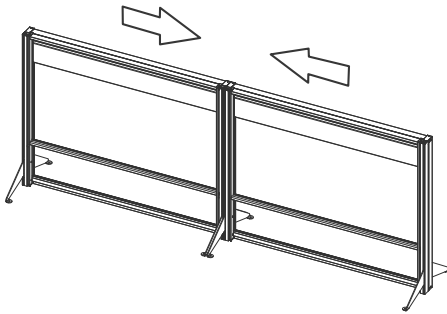

14

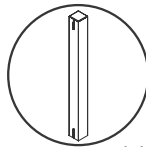
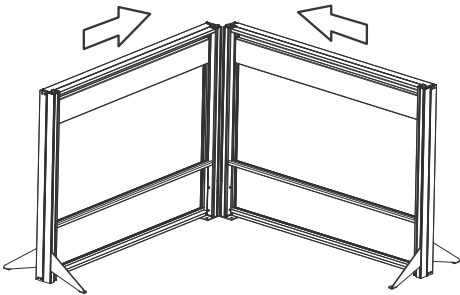

17

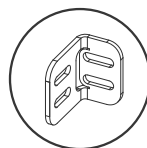
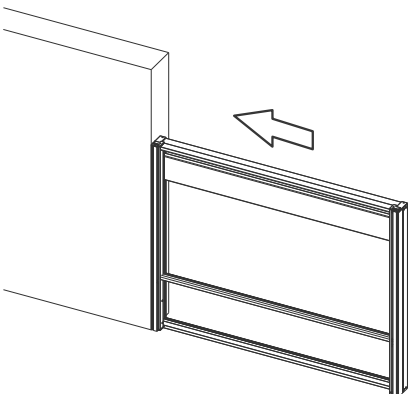

21

6

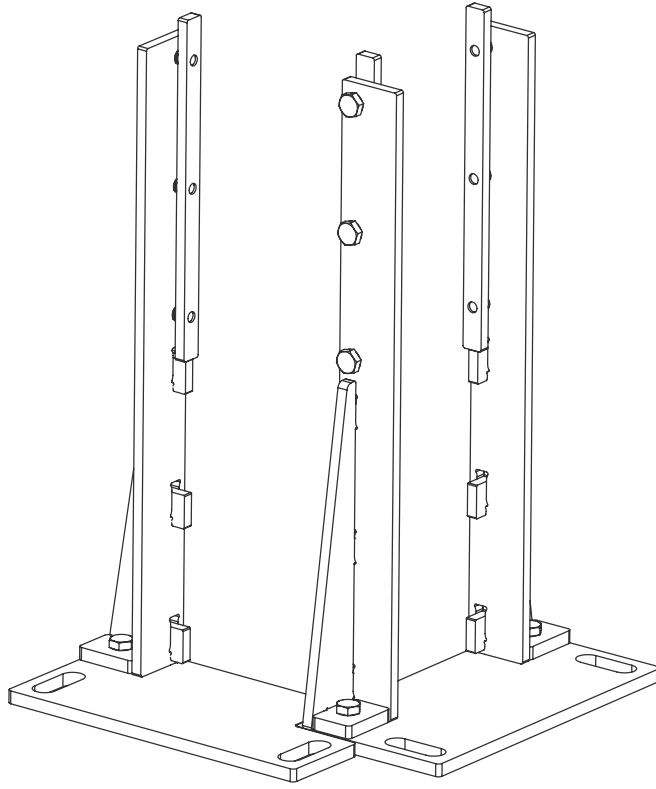
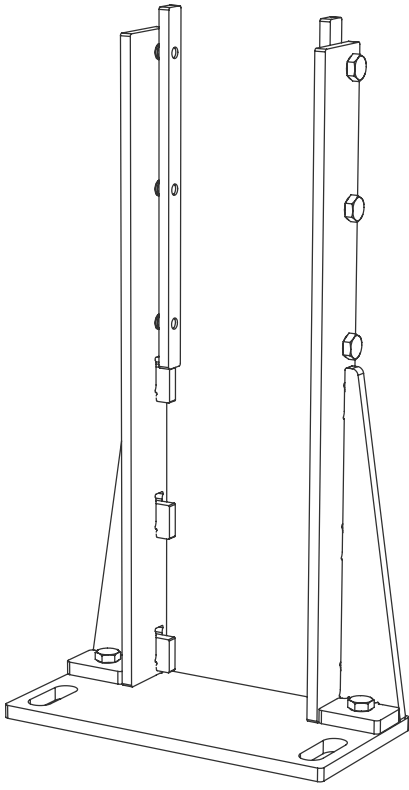

2x



6x

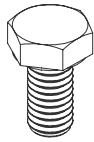

1x

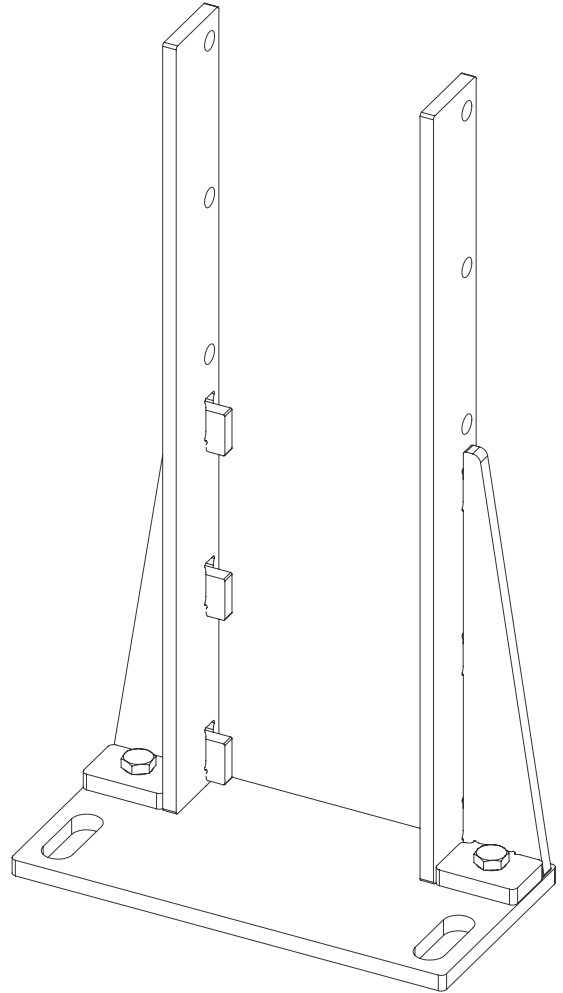

111-03201

8

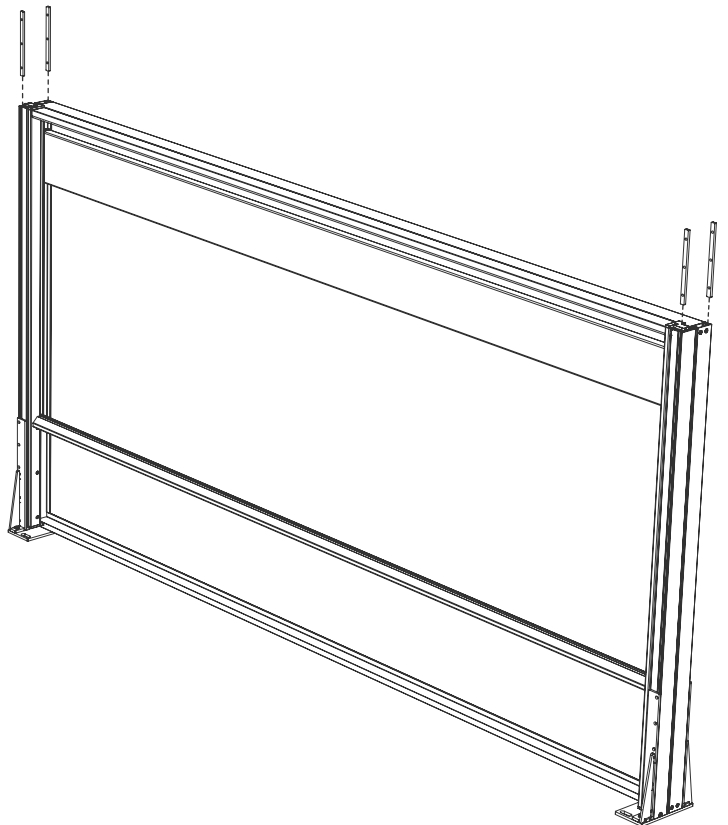
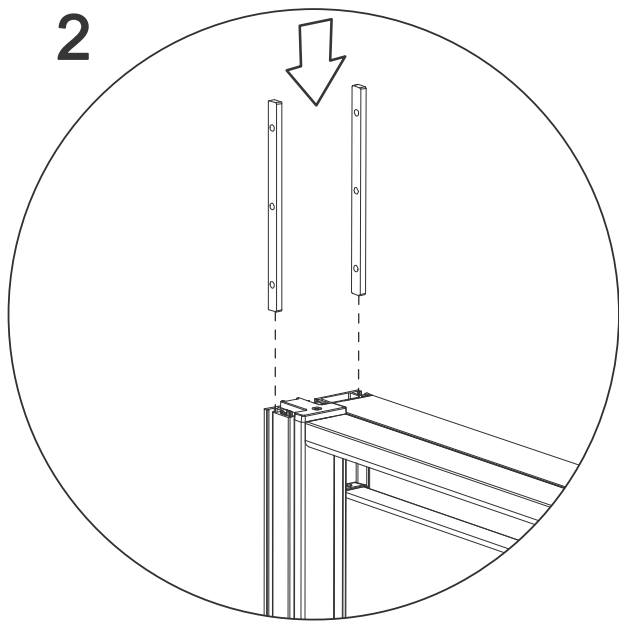
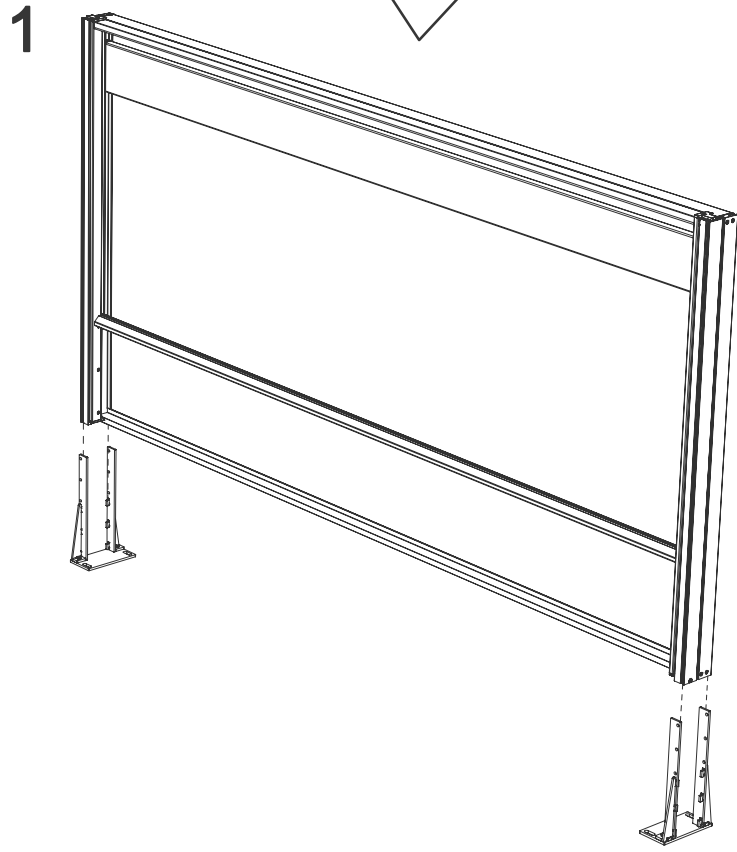

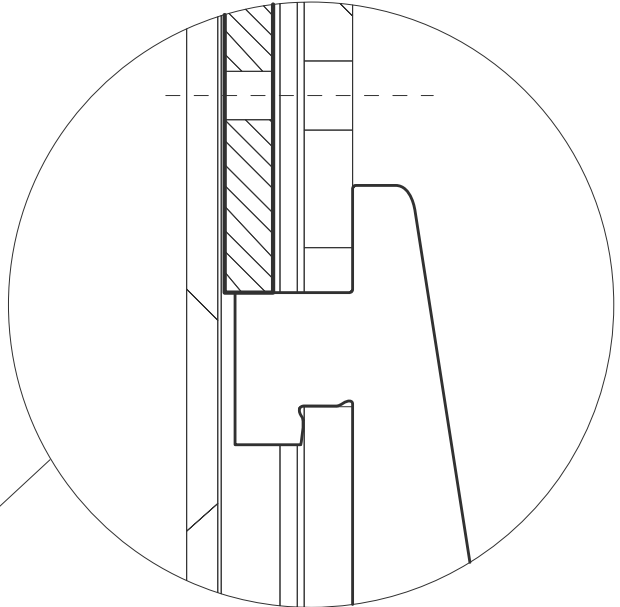
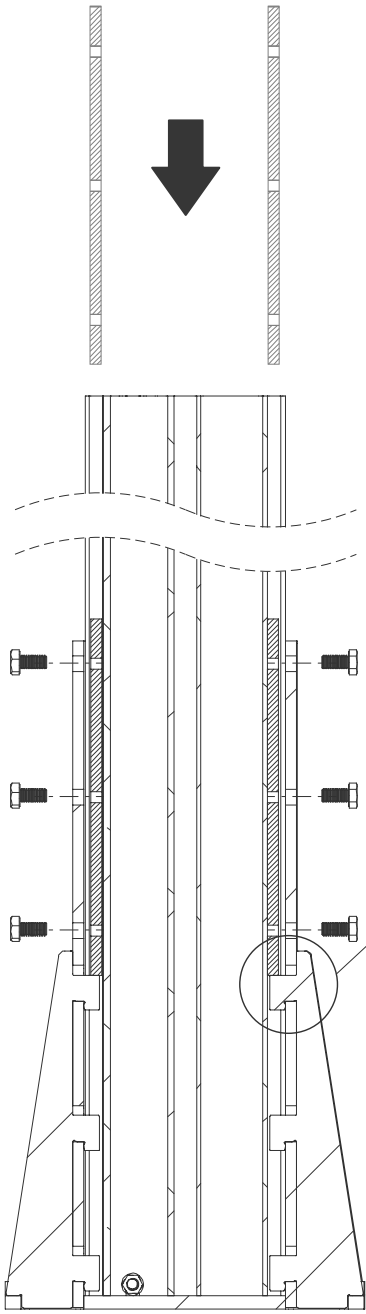

3

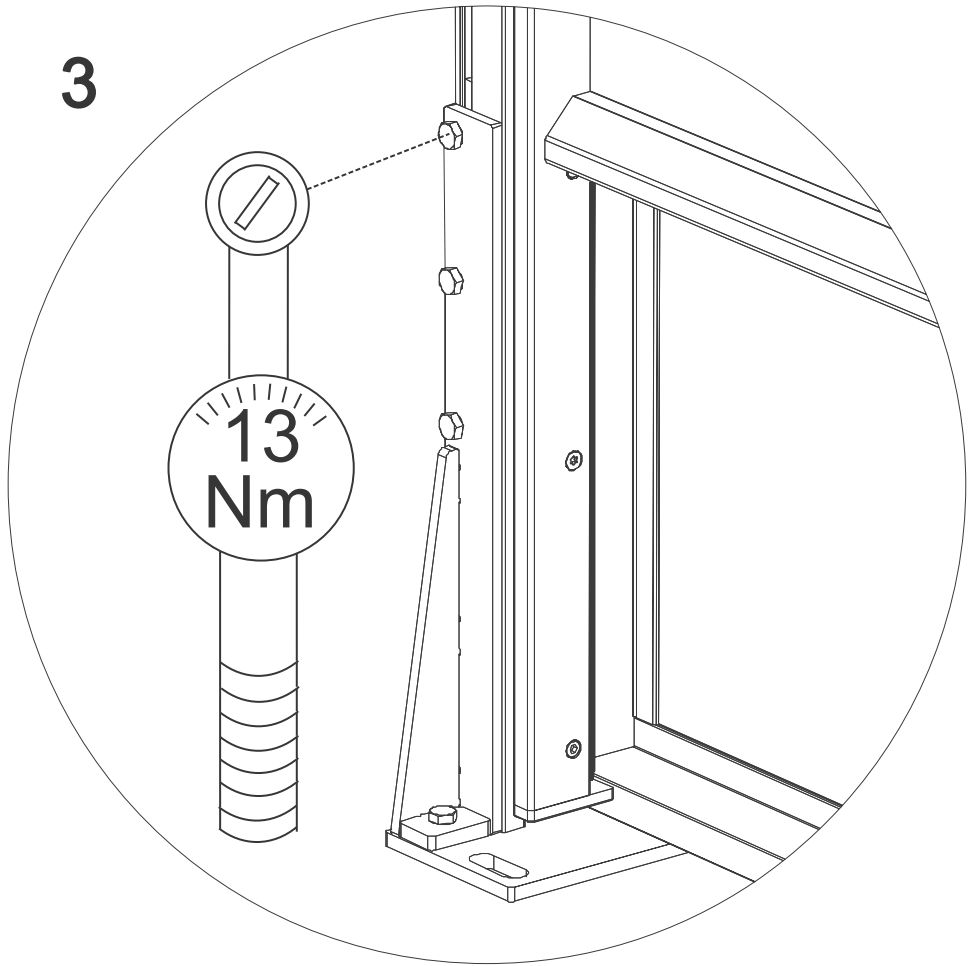

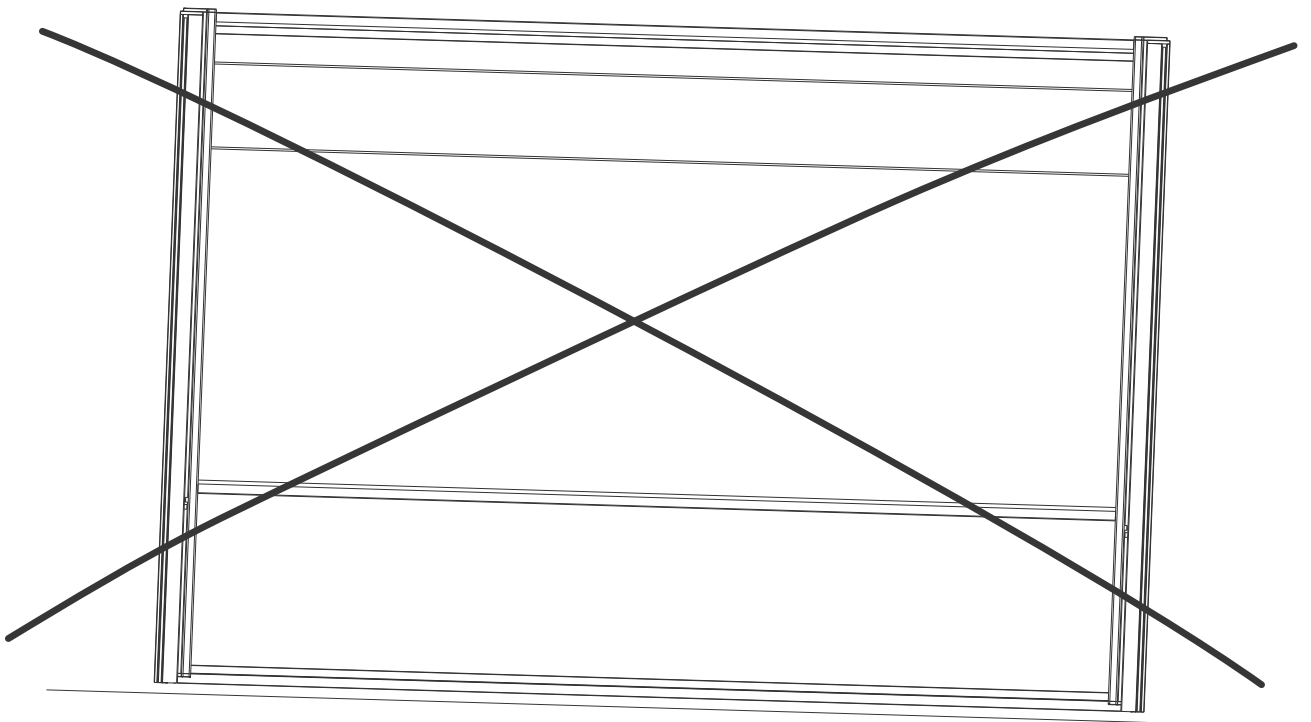
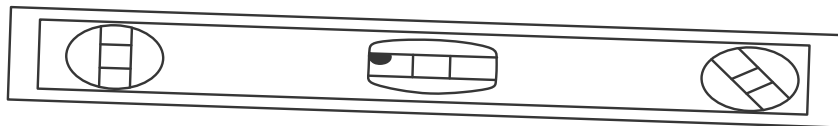
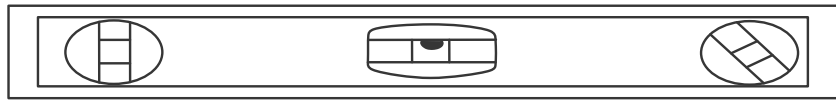

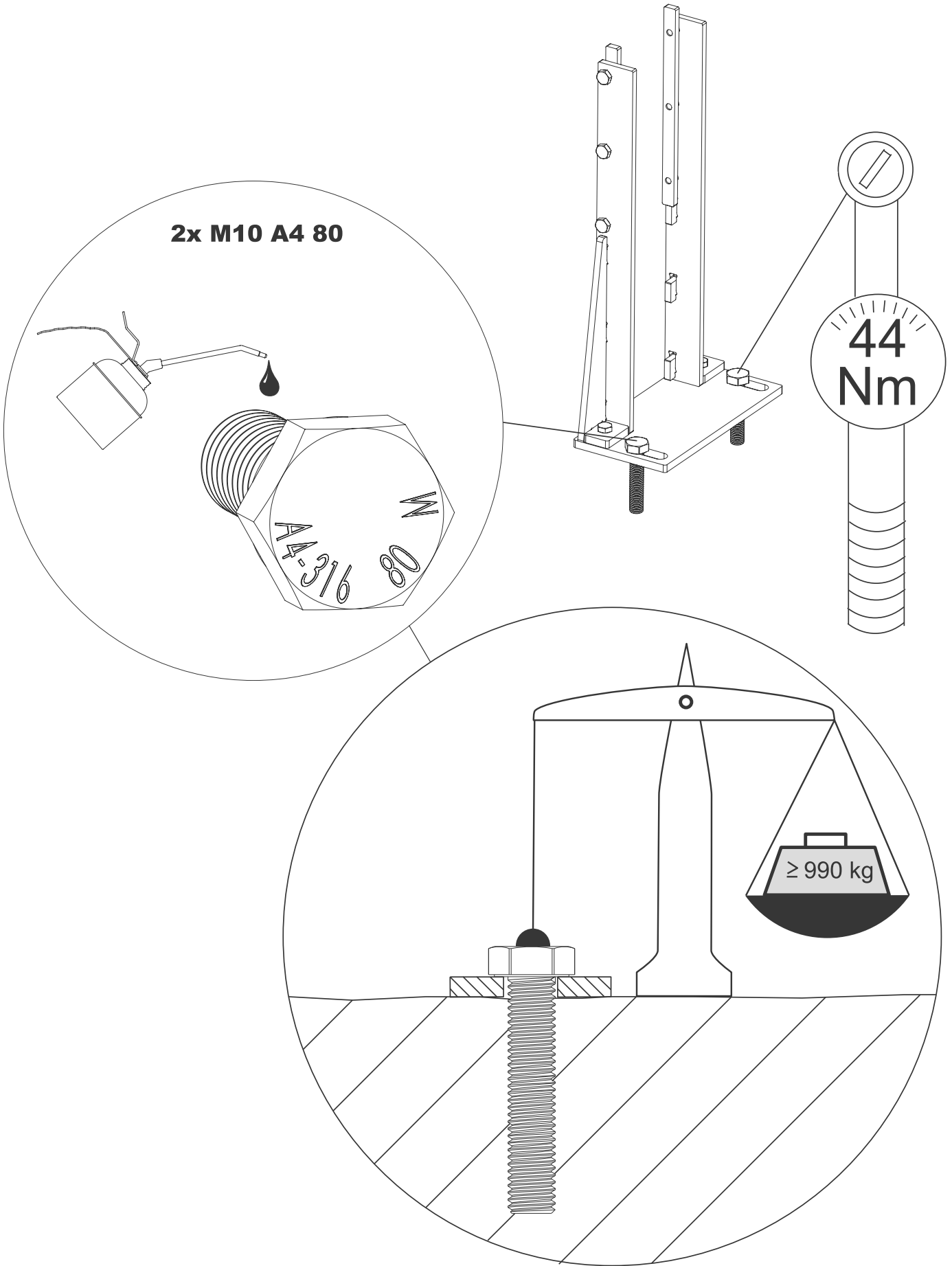

3x

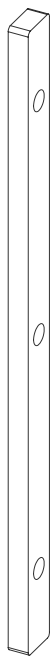

9x

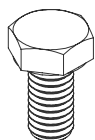

1x

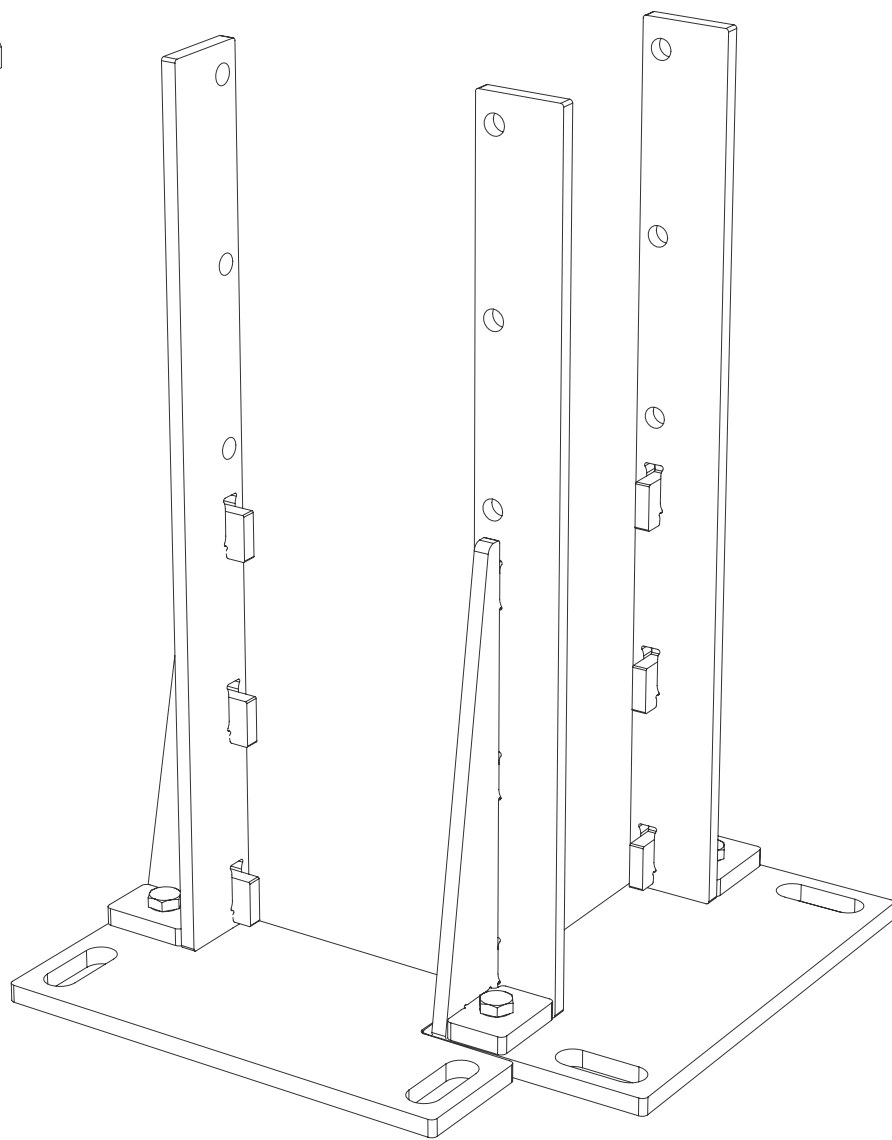

111-03219

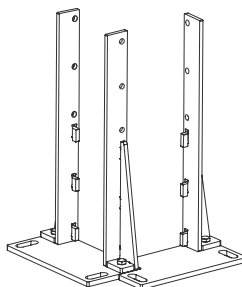
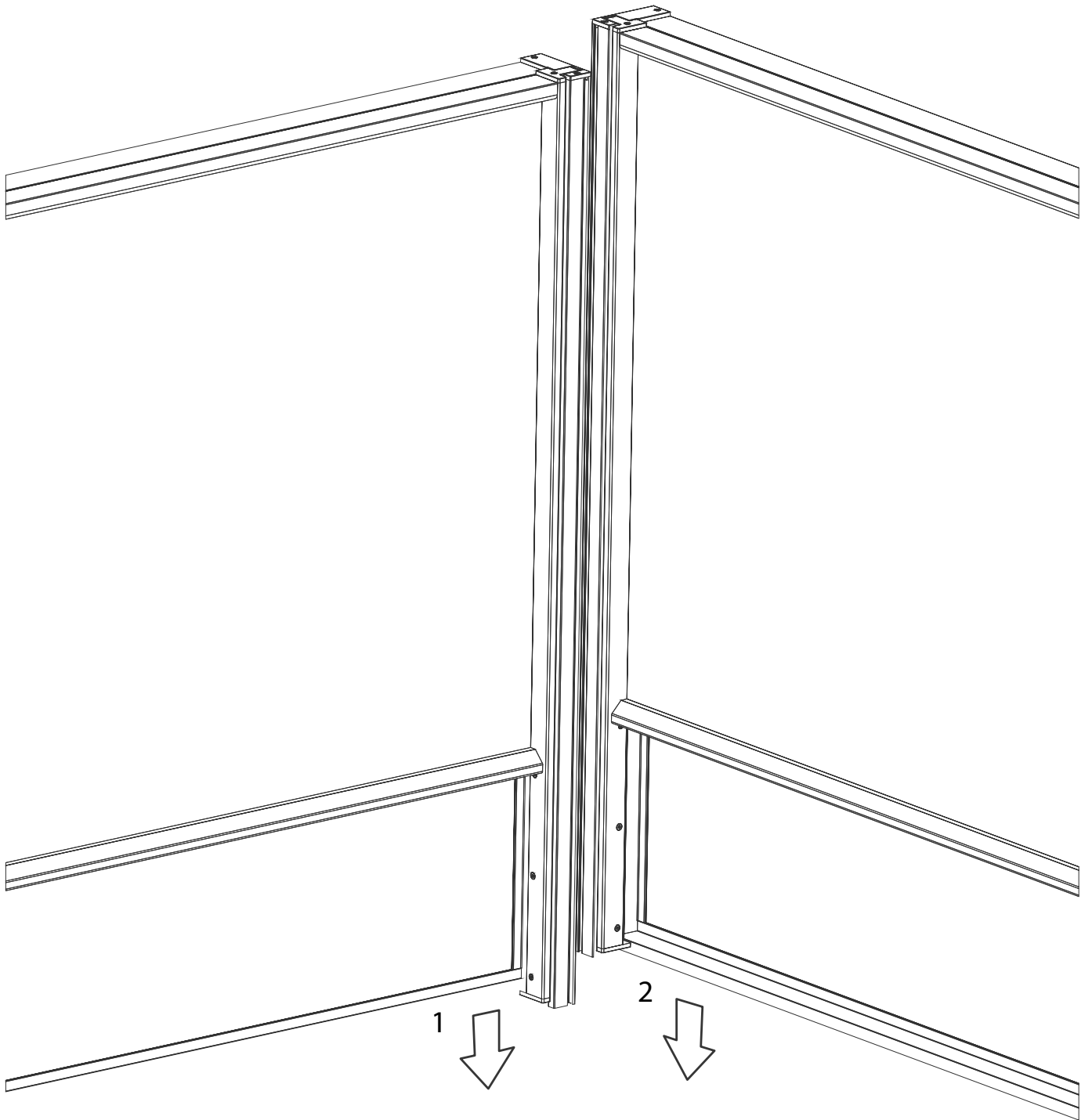

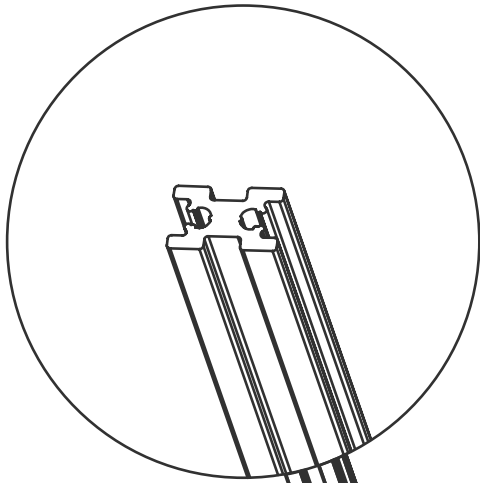

1x

111-03070

1

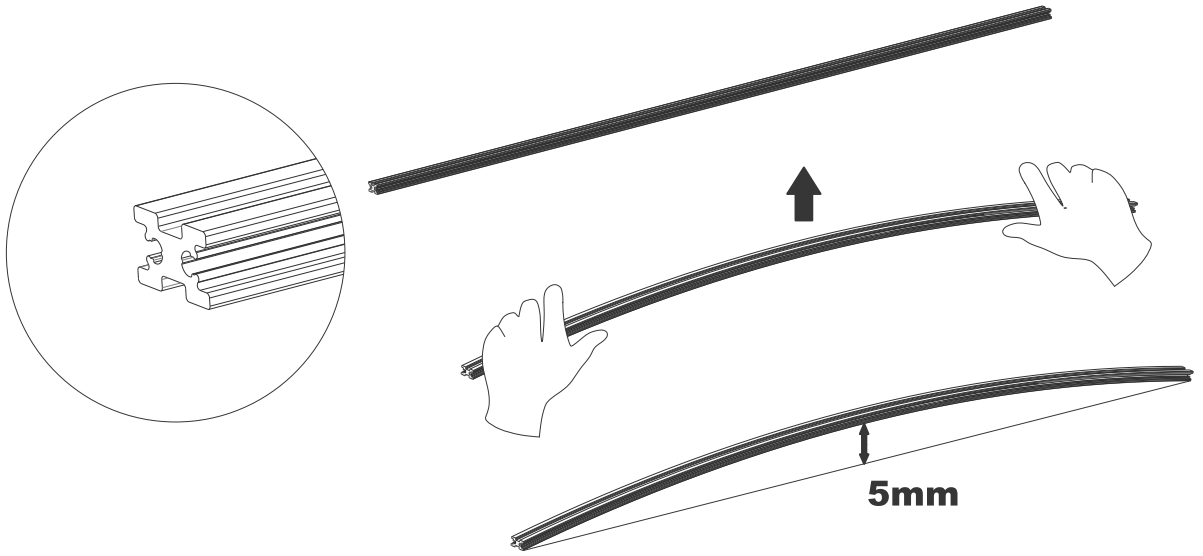

2

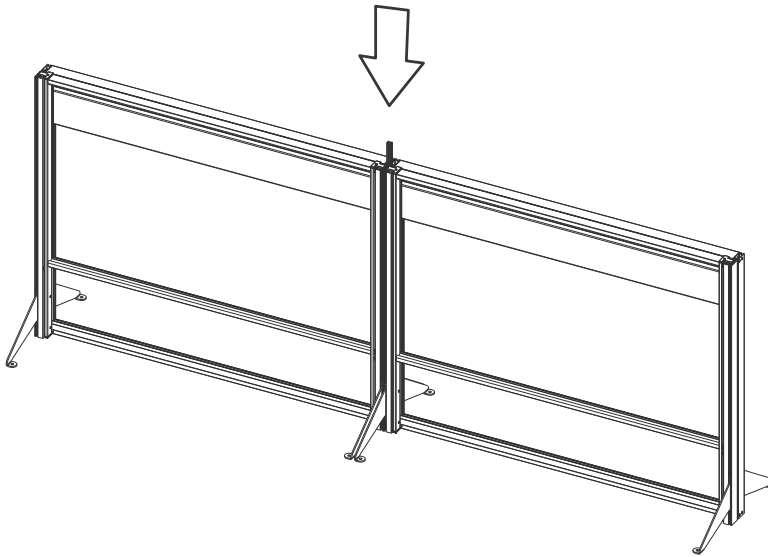

3

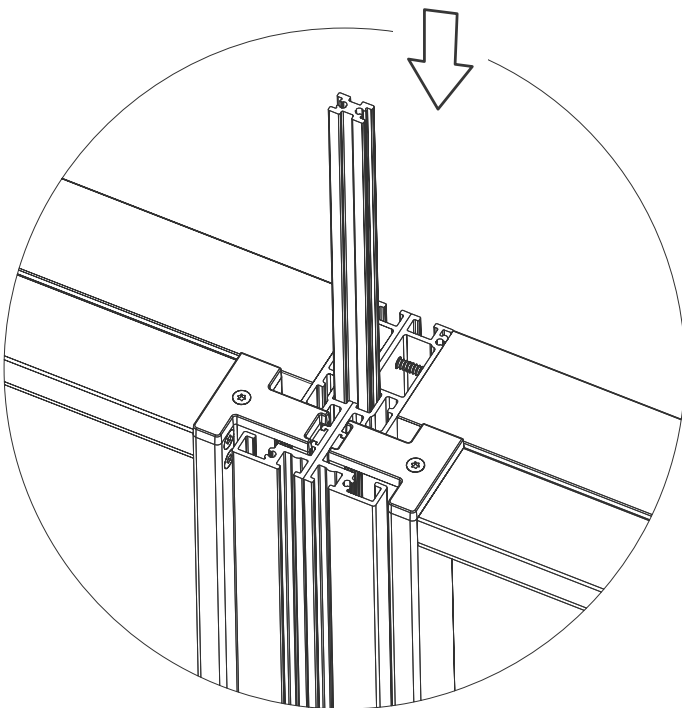

4

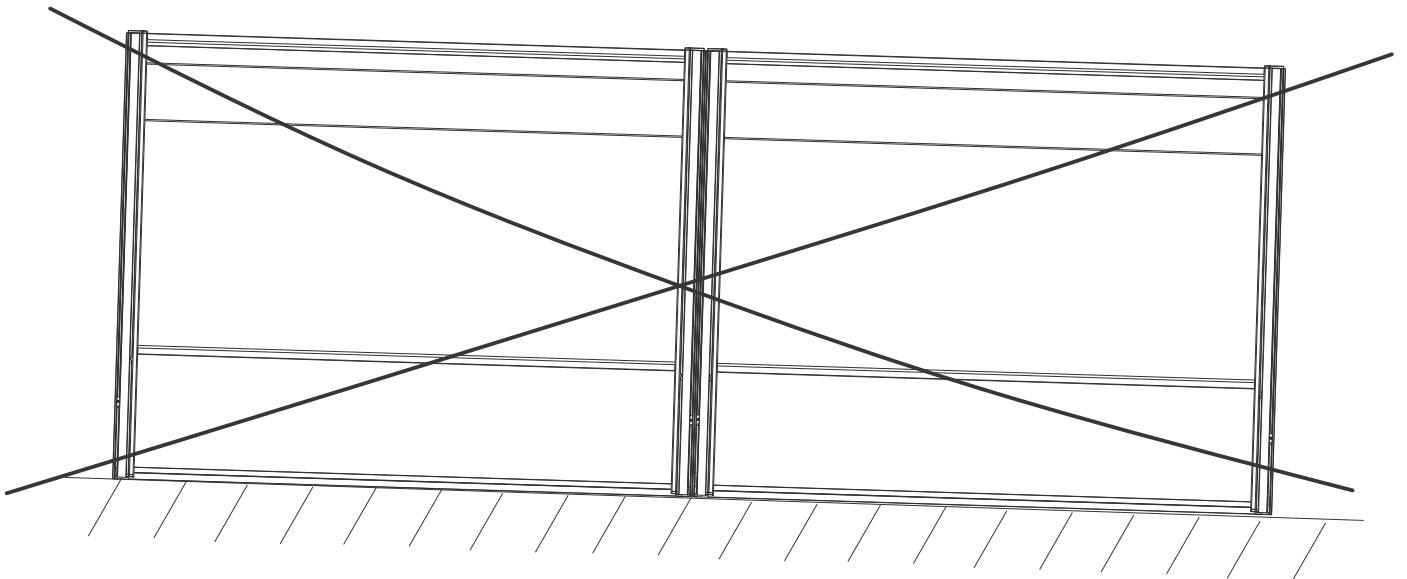
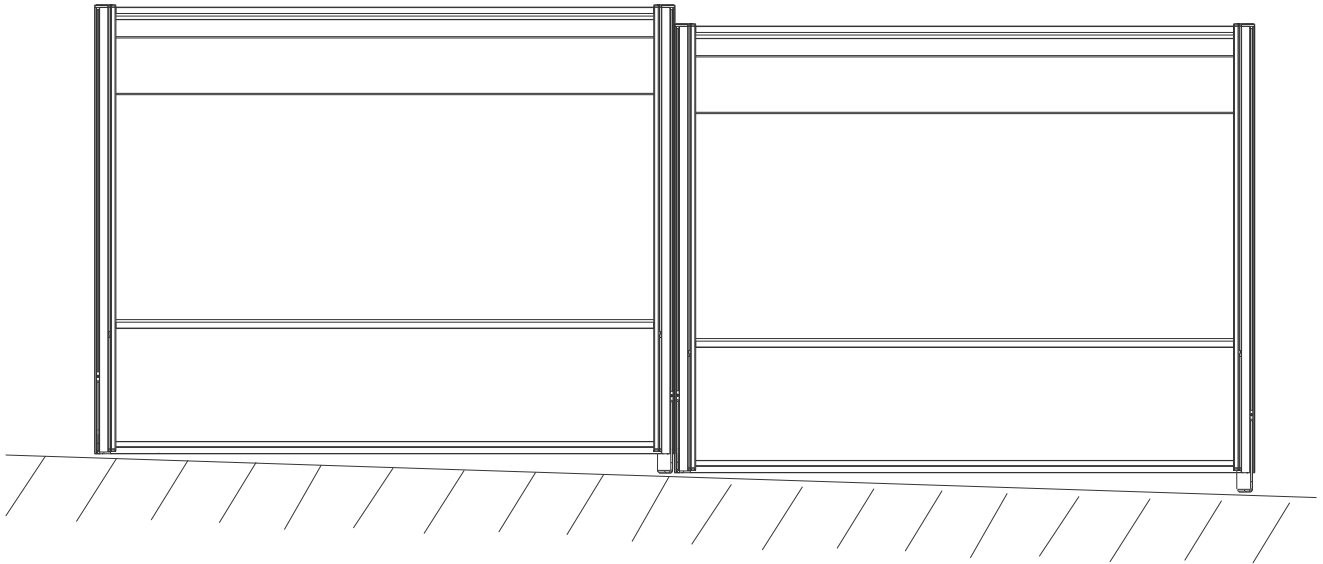
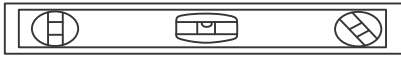



1x

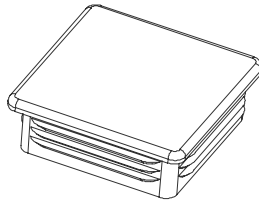

1x

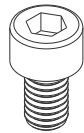

2x

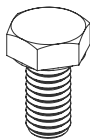

2x



4x

**111-03018/
111-03024/
111-03030**

1

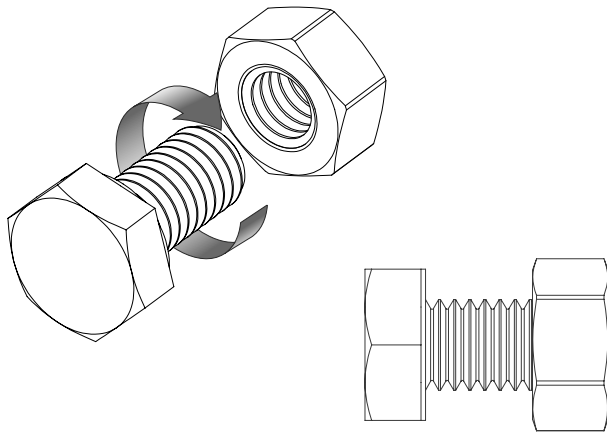

2

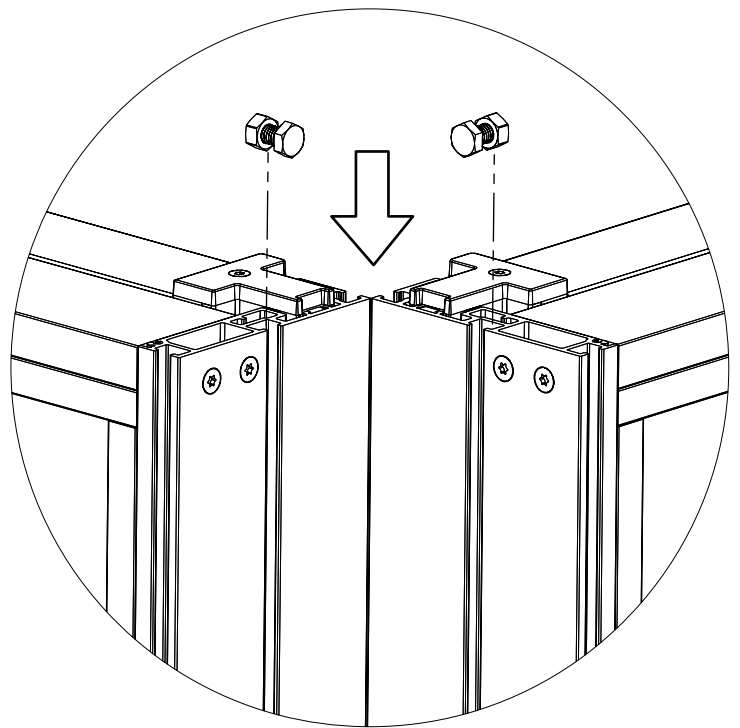

3

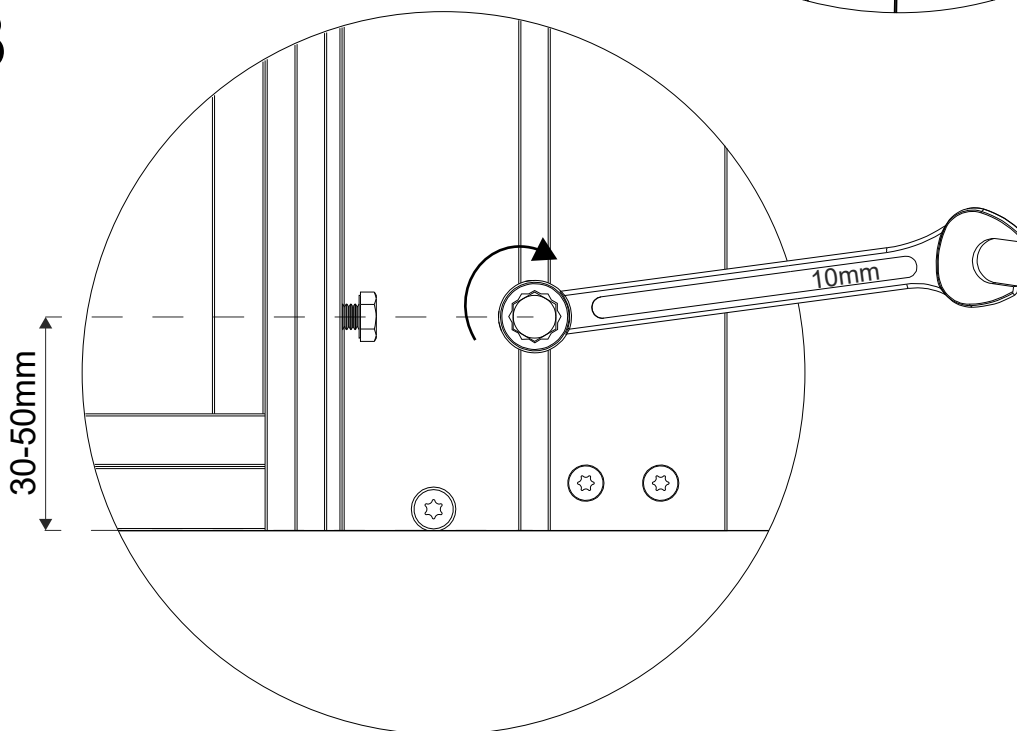

4

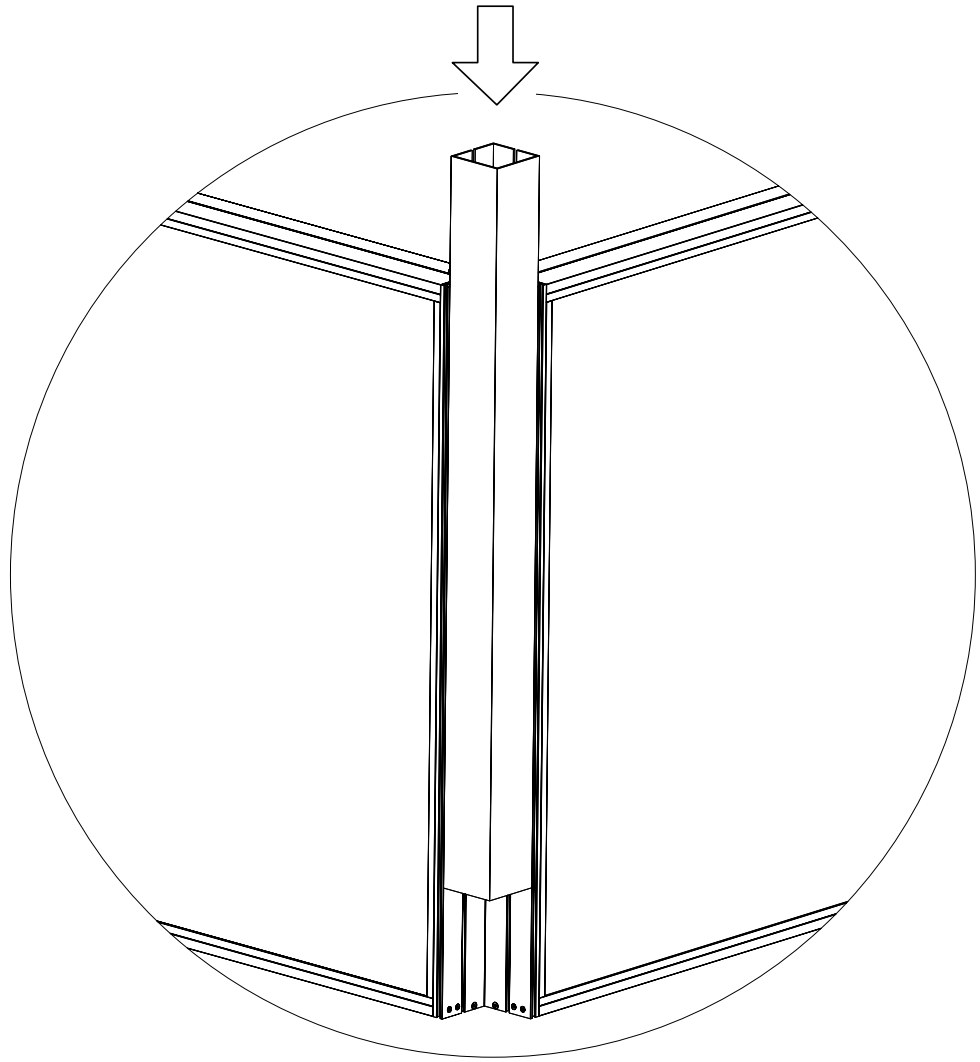

5

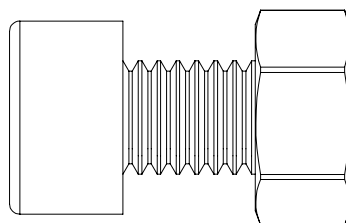
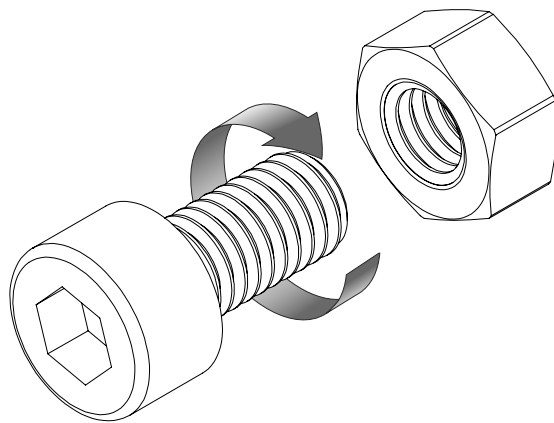

6

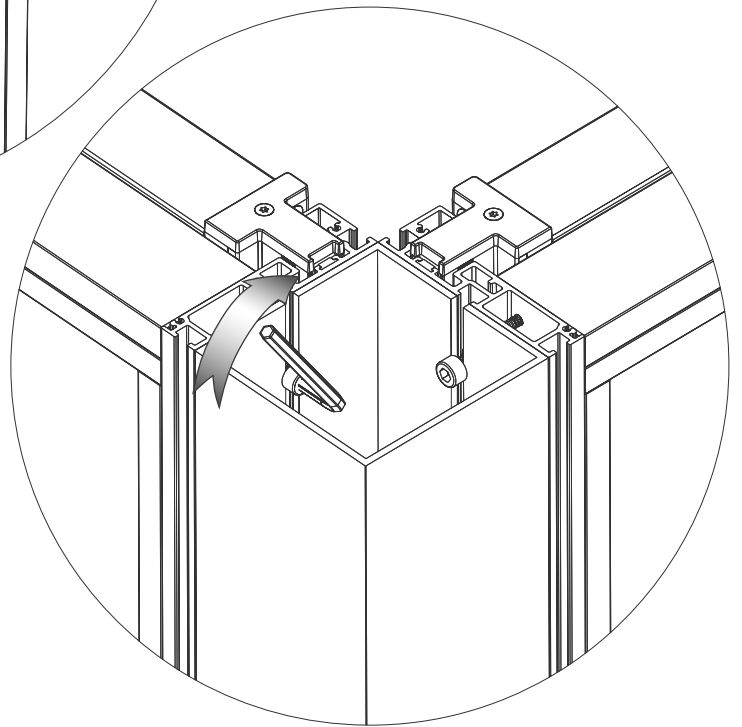
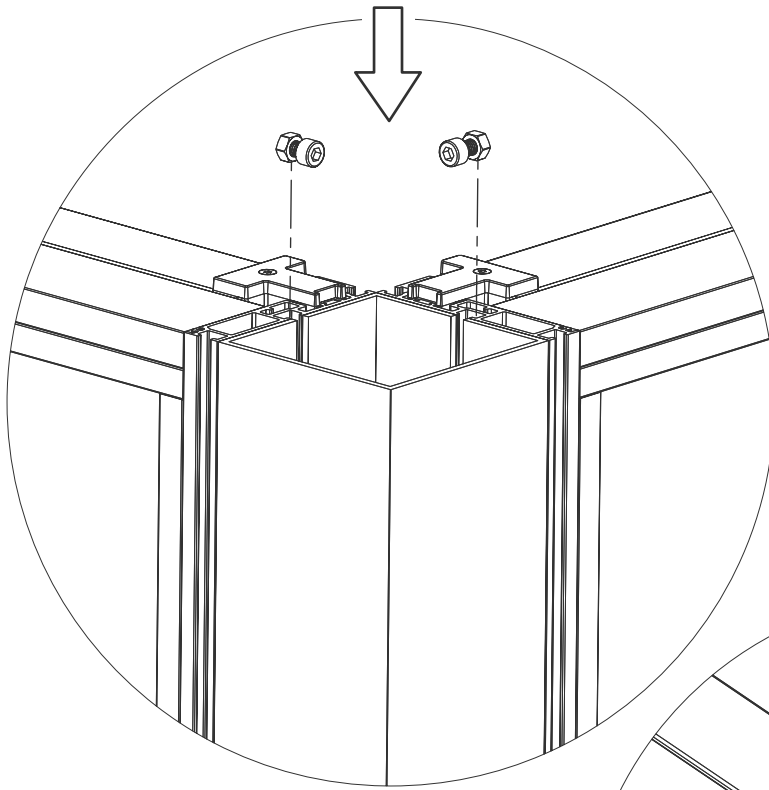

7

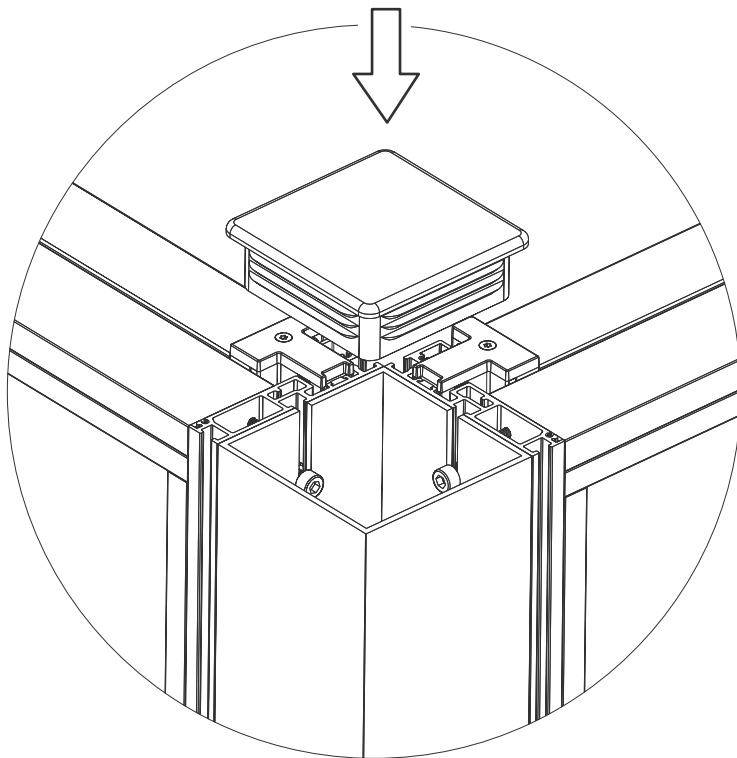

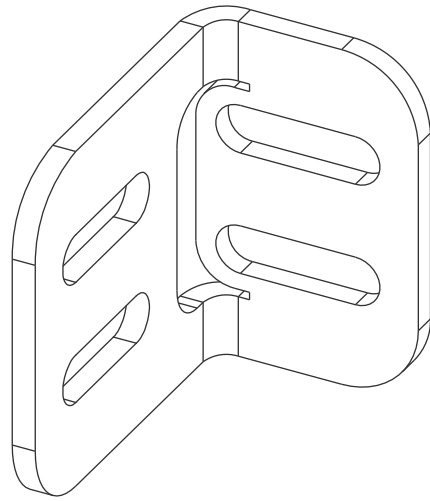

2x

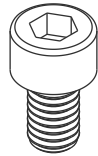

2x



2x

111-03004

1

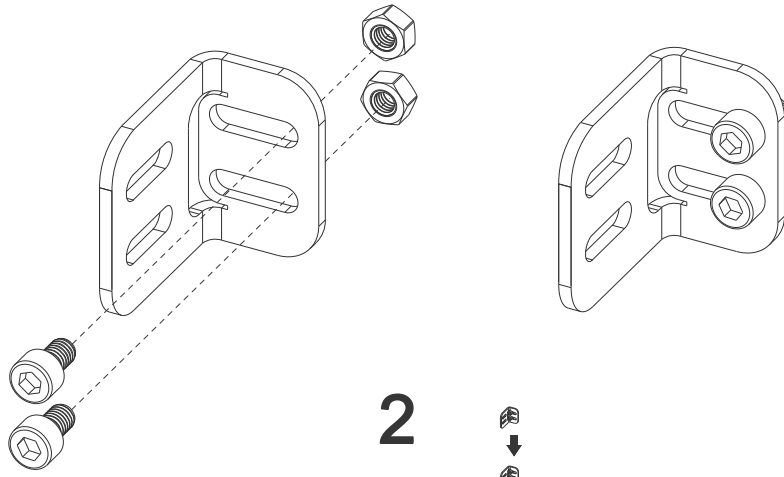

2

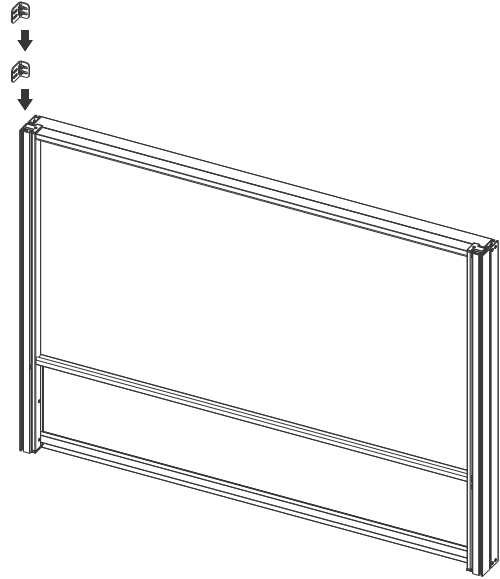

3

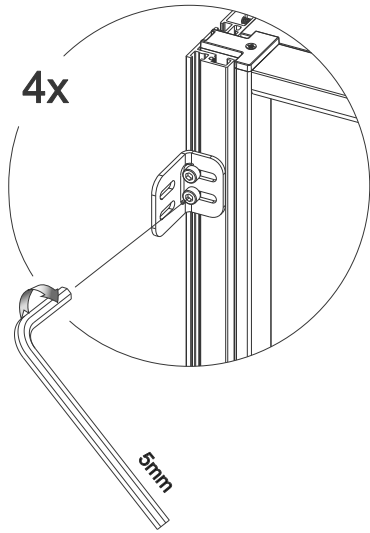

4

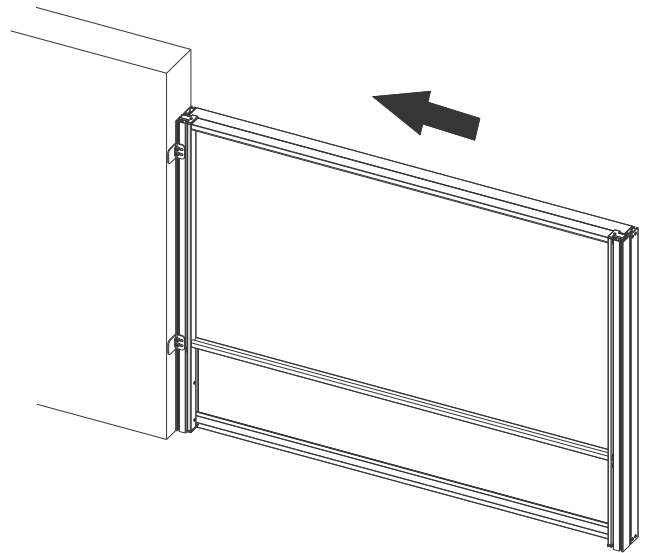

5

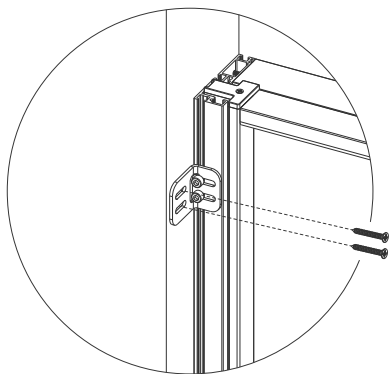

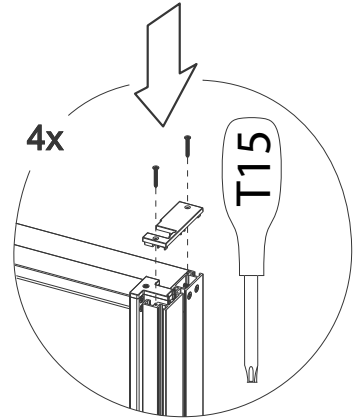
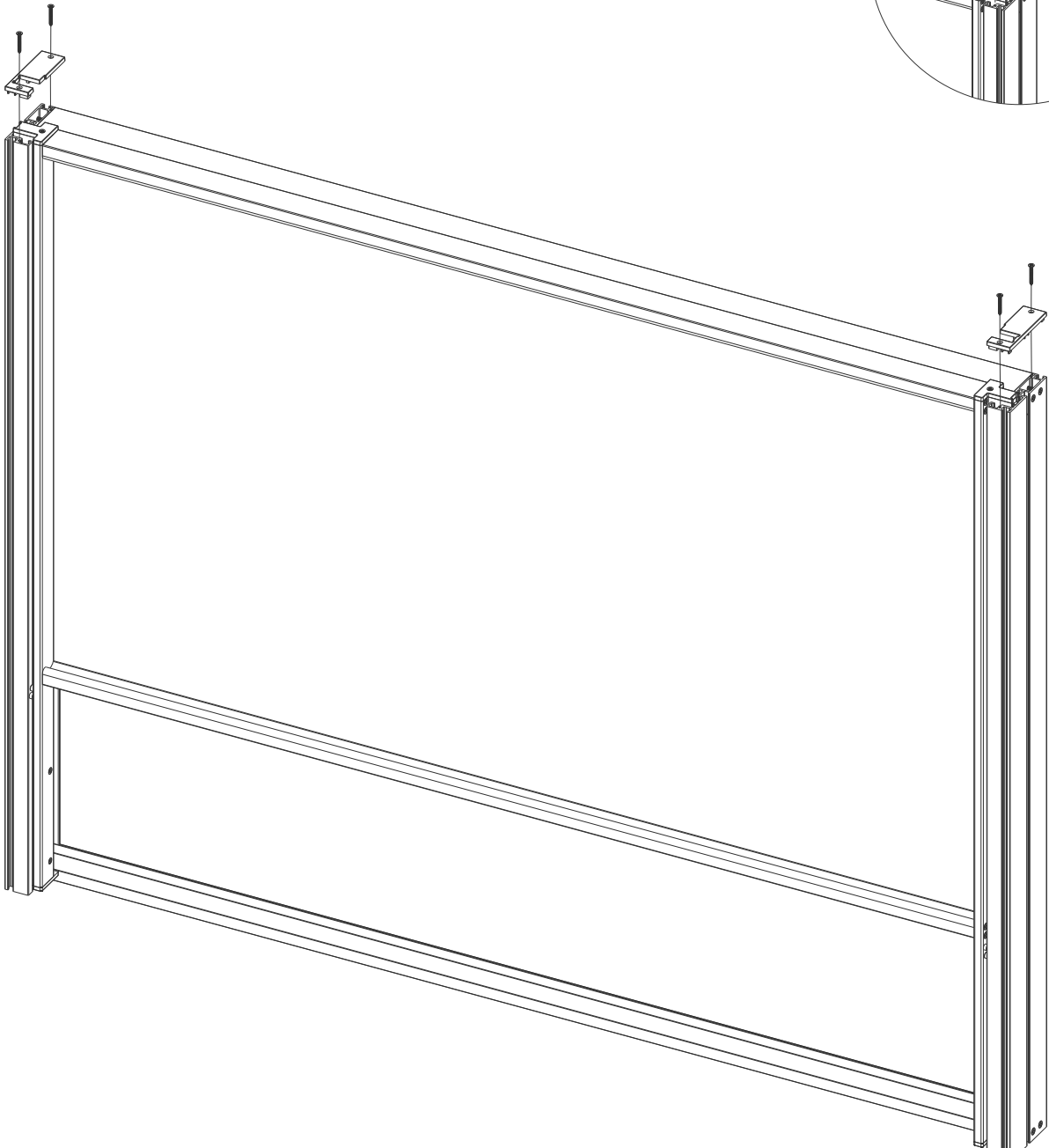

HANTERING OCH SKÖTSELRÅD

- Manövrera alltid den rörliga rutan med varsamhet, går det tungt måste justering eller rengöring utföras.
- Rörliga rutan bör alltid vara nedsänkta när Lä-partierna inte används.
- Vid kraftiga vindar (>20 m/s) måste den rörliga rutan sänkas ned för att inte riskera att skadas.
- Undvik att luta saker mot Stilje-partierna.

RENGÖRING

- Glasen rengörs med fönsterputs, starkare medel skadar listerna.
- Aluminium & plastdetaljer rengörs med icke frätande rengöring som mildt diskmedel eller såpa.
- Linor och löphjul torkas av med fuktig trasa och vatten.

RÅD OM HÅNTERING OG VEDLIKEHOLD AV STILJE GLASSREKKVERK

- Manøvrer alltid de bevegelige glassene med forsiktighet. Hvis det har tungt for å bevege seg må man justere eller rengjøre.
- De bevegelige glassene bør alltid være nedsenket når de ikke er i bruk.
- Ved sterk vind (>20 m/s) må de bevegelige glassene senkes ned, for ikke å risikere skader.
- Unngå å lene ting mot glassrekkverket.

RENHOLD

- Glassene rengjøres med vanlig vindusvaskemiddel, sterkere middel kan skade listene.
- Aluminium og plastdeler rengjøres med ikke-korrosiv rengjøring som mildt vaskemiddel eller såpe.
- Vaier og løpehjul tørkes av med en fuktig klut og vann.

KÄSITTELY- JA HOITO-OHJEET

- Käsittele aina varovasti liikkuvaa lasiruutua. Mikäli se liikkuu tahmeasti, on sitä säädettävä tai putsattava.
- Liikkuva lasiruutu on aina oltava alhaalla, kun Stilje-elementtejä ei käytetä.
- Kovan tuulen yhteydessä (>20 m/s) on liikkuva lasiruutu laskettava alas välttyäkseen vahingoittumisriskeiltä.
- Vältä esineiden nojaamista Stilje-elementteihin.

PUHDISTUS

- Lasi puhdistetaan ikkunapuhdistusaineella, vahvempi aine vahingoittaa lasitoja.
- Alumiini- & muoviyksityiskohdat puhdistetaan ei-syövyttävällä puhdistusaineella, kuten tiskiain-eella tai mäntysuovalla
- Liinat ja pyörät puhdistetaan kostealla rätillä.

Skånska Byggvaror®



GRØNT FOKUS



nordrum

Tel. 042-210 100
www.skanskabyggvaror.se

Tel. 38 18 18 18
www.grontfokus.no

Puh. 09 424 50130
www.nordrum.com