

Assembly, installation and maintenance manual

Montage-, Aufbau- und Wartungsanleitung • Assemblage, manuel de montage et d'entretien • Montaje, instalación y mantenimiento • Manuale di montaggio, installazione e manutenzione • Monterings- og vedlikeholdsmanual • Monterings-, installations- och underhållsmanual • Kokoamis-, asennus- ja huolto-ohje • Vejledning for montering og vedligehold • Handleiding voor montage, installatie en onderhoud • Manual de montagem, instalação e manutenção • Návod k montáži, instalaci a údržbě • Instrukcja montażu, instalacji i konserwacji • Surinkimo, montavimo ir priežiūros vadovas • Montāžas, uzstādīšanas un apkopes rokasgrāmata • Руководство по сборке и обслуживанию • Montaaži-, paigaldus- ja säilitamise juhend



Pavilion PA44-4242

<p>Factory inspection by • Werkskontrolle durch • Contrôle à partir de l'usine par • Inspector de fábrica • Collaudato da • Fabrikkontroll utført av • Fabriksbesiktigat av • Tehtaan tarkastaja • Fabriks Kontrol udført af • Fabrikscontrole door • Inspeção de fábrica, por: • Zkontrolováno ve výrobním závodě • Kontrola fabryczna do • Apžiūrą gamykloje atliko • Rūpnīcas pārbaudi veicis • Заводской контроль • Tehase kontroll teostatud:</p> <p>.....</p>	<p>Date • Datum • Date • Fecha • Data • Dato • Datum • Päiväys • Dato • Datum • Data • Datum • Data • Datums • Data • Дата • Kuupäev:</p>
	<p>Pack number • Pack Nr. • Packet n° • Bulto N° • Pacco N. • Serienr • Produktionsnummer • Pakettinro • Pakke nr. • Pak nr. • Número de embalagem • Číslo balení • Numer opakowania • Pakotės numeris • Iepakojuma numurs • Упаковочный номер • Pakinumber:</p>



www.palmako.ee/information-hub

English: Before installing and using the product, please read the instructions and warranty terms at www.palmako.ee/information-hub to guarantee proper installation and long-lasting performance.

Deutsch: Wichtig! Bitte vor Aufbau und Nutzung des Produkts unbedingt die detaillierte Montageanleitung sowie die Garantiebedingungen unter www.palmako.ee/information-hub lesen, um eine fachgerechte Montage und eine lange Funktionssicherheit zu gewährleisten.

Français: Avant d'installer et d'utiliser le produit, veuillez lire les instructions et les conditions de garantie sur www.palmako.ee/information-hub afin de garantir une installation correcte et la longévité du produit.

Español: Antes de instalar y utilizar el producto, lea las instrucciones y las condiciones de garantía en www.palmako.ee/information-hub para asegurar una instalación correcta y una larga vida útil del producto.

Italiano: Prima di installare e utilizzare il prodotto, leggere le istruzioni e le condizioni di garanzia su www.palmako.ee/information-hub per garantire una corretta installazione e prestazioni durature.

Norsk: Før montering og bruk av produktet, vennligst les monteringsanvisningene og garantivilkårene på www.palmako.ee/information-hub for å sikre korrekt montering og fremtidig holdbarhet.

Svenska: Innan du installerar och använder produkten, vänligen läs instruktionerna och garantivillkoren på www.palmako.ee/information-hub för att säkerställa korrekt installation och produktens långvariga hållbarhet

Suomi: Ennen tuotteen asentamista ja käyttämistä, lue ohjeet ja takuehdot osoitteessa www.palmako.ee/information-hub varmistaaksesi oikean asennuksen ja pitkäkestoisen toiminnan.

Русский: Перед установкой и использованием изделия ознакомьтесь с инструкцией и условиями гарантии на сайте www.palmako.ee/information-hub, чтобы гарантировать правильную установку и долговечность изделия.

Eesti: Enne toote paigaldamist ja kasutuselevõttu lugege palun juhiseid ja garantiitingimusi aadressil www.palmako.ee/information-hub, et tagada nõuetekohane paigaldus ja toote pikk eluiga.

Dansk (Oversat af AI): Læs venligst instruktionerne og garantibetingelserne på www.palmako.ee/information-hub, før du installerer og bruger produktet, for at garantere korrekt installation og langvarig ydeevne.

Dutch (Vertaald door AI): Lees vóór de installatie en het gebruik van het product de instructies en garantievoorwaarden op www.palmako.ee/information-hub om een correcte installatie en langdurige werking te garanderen

















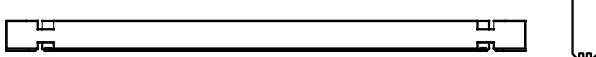
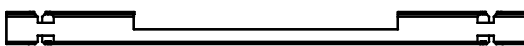



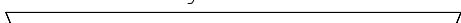
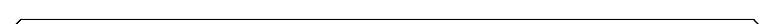
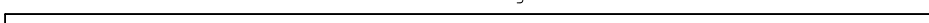

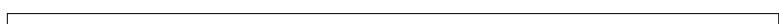
Português (Traduzido por IA): Antes de instalar e utilizar o produto, leia as instruções e os termos de garantia em www.palmako.ee/information-hub para garantir uma instalação adequada e um desempenho duradouro.









Čeština (Přeloženo umělou inteligencí): Před instalací a použitím produktu si prosím přečtěte pokyny a záruční podmínky na www.palmako.ee/information-hub, abyste zaručili správnou instalaci a dlouhodobý výkon.

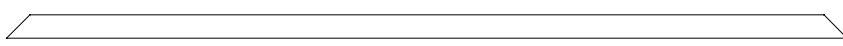
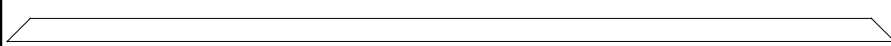
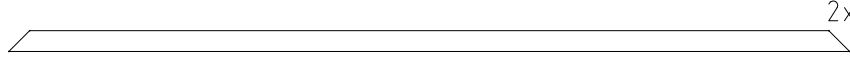

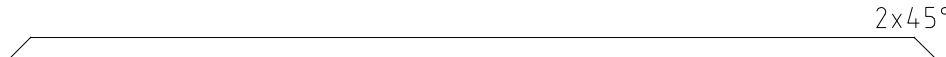
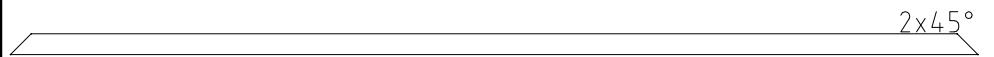

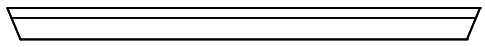



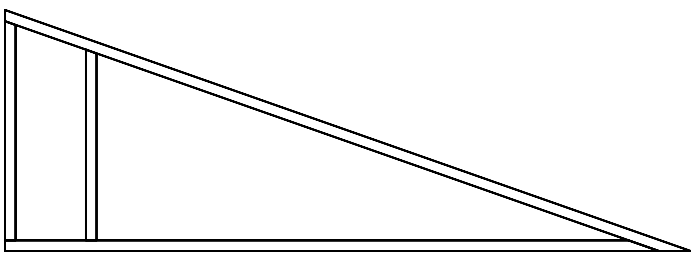
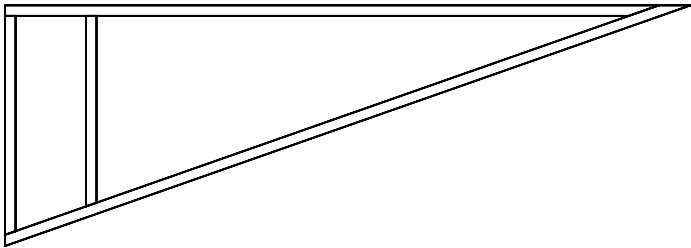
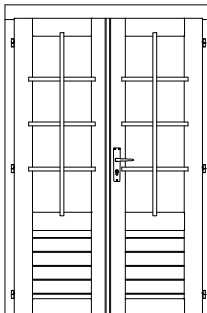
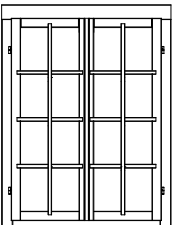

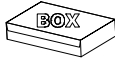









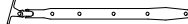

Polski (Przetłumaczone przez AI): Przed zainstalowaniem i użyciem produktu należy przeczytać instrukcję oraz warunki gwarancji dostępne na stronie www.palmako.ee/information-hub, co pozwoli zagwarantować prawidłową instalację i długotrwałą wydajność.

Latviešu (Mākslīgā intelekta tulkojums): Pirms produkta uzstādīšanas un lietošanas, lūdzu, izlasiet instrukcijas un garantijas noteikumus vietnē www.palmako.ee/information-hub, lai garantētu pareizu uzstādīšanu un ilgstošu darbību.

Lietuviškai (Išvertė DI): Prieš montuodami ir naudodami gaminį, perskaitykite instrukcijas ir garantijos sąlygas adresu www.palmako.ee/information-hub, kad užtikrintumėte tinkamą montavimą ir ilgalaikį veikimą.

Pos	SPECIFICATION-STÜCKLISTE-NOMENCLATURE-ELEMENTI-ESPECIFICACIÓN- MÄÄRITYS- SPECIFIKATION PA44-4242	Pcs	Profile (mm)	Length (mm)
001		3	44x55	1985
001a		1	44x55	367
001b		1	44x55	367
002		17	44x114	367
003		17	44x114	367
004		81	44x114	1985
005		4	44x114	1985
006		2	44x114	1985
007		46	44x114	487
008		46	44x114	487
009		2	44x114	1985
010		4	44x55	1985
AR1	Foundation- Fundament- Fondation- Fondazione- Vigas de cimentación- Perustus- Grund 2x68° 	8	60x80	1741
AR2	Foundation- Fundament- Fondation- Fondazione- Vigas de cimentación-Perustus- Grund 2x45° 	2	60x80	2943
AR3	Foundation- Fundament- Fondation- Fondazione- Vigas de cimentación - Perustus- Grund 2x90° 	4	60x80	4083
060	Floor board- Fussbodenbrett- Madrier du plancher - Tavola pavimento- Tabla de suelo- Lattialauta- Golvbräda 			
061	 2x90°	19	19x89	4115
062	  2x45°	2	19x89	1780
063	 2x45°	2	19x89	1959
064	 2x45°	2	19x89	2139
065	 2x45°	2	19x89	2318
066	 2x45°	2	19x89	2498
067	 2x45°	2	19x89	2677
068	 2x45°	2	19x89	2857
069	 2x45°	2	19x89	3036

Pos	SPECIFICATION-STÜCKLISTE-NOMENCLATURE-ELEMENTI-ESPECIFICACIÓN- MÄÄRITYS- SPECIFIKATION PA44-4242	Pcs	Profile (mm)	Length (mm)
0610	 2x45°	2	19x89	3216
0611	 2x45°	2	19x89	3395
0612	 2x45°	2	19x89	3575
0613	 2x45°	2	19x89	3754
0614	 2x45°	2	19x89	3934
0615	 2x45°	2	19x89	4113
150	Joining detail- Verbindungsteil- Détail de connection- Dettaglio di collegamento- Detalle de juntura- Liitososa- Tillhörande list 	4	8x16	1200
100		8	19x95	2084
151		8	44x120	1808
130	Floor beading- Fussbodenleiste- Baguette du plancher- Listello pavimento- Listón de suelo- Lattialista- Golvlister 	8	19x19	1800
140	Storm brace- Sturmleiste- Protection contre le vent- Antivento- Protector contra tormentas- Myrskytuki- Stormstöd 	16	19x45	2170
156	Slat- Leiste- Baguette- Listello- Listón- Lista- Spjåla 	1	19x45	1250
	Roof element- Dachelement- Panneau de toit- Elemento di tetto- Elemento tejado- Kattoelementti 	8	61x1030	2918
	Roof element- Dachelement- Panneau de toit- Elemento di tetto- Elemento tejado- Kattoelementti 	8	61x1030	2918
TU44-111P TA44-37P	Door - Tür - Porte - Porta-Puerta - Ovi - Dörr 1244x1936 Window - Fenster - Fenetre - Finestra-Ventana- Ikkuna- Fönster 1003x1336  	1 4		

Pos	SPECIFICATION-STÜCKLISTE-NOMENCLATURE-ELEMENTI-ESPECIFICACIÓN- MÄÄRITYS- SPECIFIKATION PA44-4242	Pcs	Profile (mm)	Length (mm)	
	-Fixing kit- Befestigungsset- Moyens de fixation- Materiale di fissaggio- Kit de fijación- Kiinnityssarja- Infästningssats		1	USE	
QULSI 30x35	Cylinder- Zylinderschloss- Serrure a mortaiser- Serratura a cilindro- Bombin- Sylinteri- Cylinder 30.35		1	TU44-111P	
QLIU KAPal	Door fittings- Türbeschlag- Ferrure- Ferramenta porta - Manilla puerta- Ovihelat- Dörrbeslag- QLIUKAPAL		1	TU44-111P	
QLIA	Window fittings- Fenstergriff- Poigne de la fenêtre- Maniglia finestra- Manilla (ventana)- Ikkunahelat- Fönsterbeslag		8	TA44-37P	
QKRPP 2_5x16 Zn	Screw- Schraube- Vis- Vite- Tornillo- Ruuvi- Skruv 2.5x16mm		2		
QKRPP 3x16Zn	Screw- Schraube- Vis- Vite- Tornillo- Ruuvi- Skruv 3x16mm		80	TU44-111P TA44-37P	
QKRPP 3x20Zn	Screw- Schraube- Vis- Vite- Tornillo- Ruuvi- Skruv 3x20mm		4		
QKRPP 4_5x50 Zn	Screw- Schraube- Vis- Vite- Tornillo- Ruuvi- Skruv 4.5x50mm		30	100	
QKRPP 4_5x70 Zn	Screw- Schraube- Vis- Vite- Tornillo- Ruuvi- Skruv 4.5x70mm		8	001+AR1	
QKRPP 5x90Zn	Screw- Schraube- Vis- Vite- Tornillo- Ruuvi- Skruv 5x90mm		140	Roof elements	
QKRPP 6x120Zn	Screw- Schraube- Vis- Vite- Tornillo- Ruuvi- Skruv 6x120mm		52	ARx, 151+005 (010)	
QNA 1_4x40Me	Nail- Nagel- Clou- Chiodo- Clavo- Naula- Spik 1.4x40mm		30	130	
QNA 2_2x50Zn	Nail- Nagel- Clou- Chiodo- Clavo- Naula- Spik 2.5x50mm		300	06x	
QFK240 MU	Window stop- Fensterfeststelle- Crémaillere- Fissativo finestra- Fijador de ventana- Ikkunan rajoitin-Fönsterstopp QAF240MU		8	TA44-37P	
QK08	Roof cap- Dachkappe- Finition métallique- Finitura di tetto- Caballete de tejado- Tuuletusputken hattu- Takåstäckning		1		
QRV120 Zn	Keeper- Schliessblech- Tole- Lamiera- Aldaba de candado- Pidike- Hållare		1	TU44-111P	
QMUKK 6Zn	Nut- Schraubenmutter- Écrou- Dado- Tuerca- Mutteri- Mutter M6mm		24		
QPOYP6 x110Zn	Bolt -Schloss-schraube -Boulon- Bullone- Perno- Pultti- Bult M6x110mm		24	140	
QSE6x 18Zn	Washer- Dichtscheibe- Joint- Rondella- Arandela- Aluslevy- Bricka 6x18mm		48		
QT18	Seal- Gummidichtung- Joint d'isolation- Guarnizione- Burlete- Tiiviste- Tätning		1	TU44-111P TA44-37P	27000

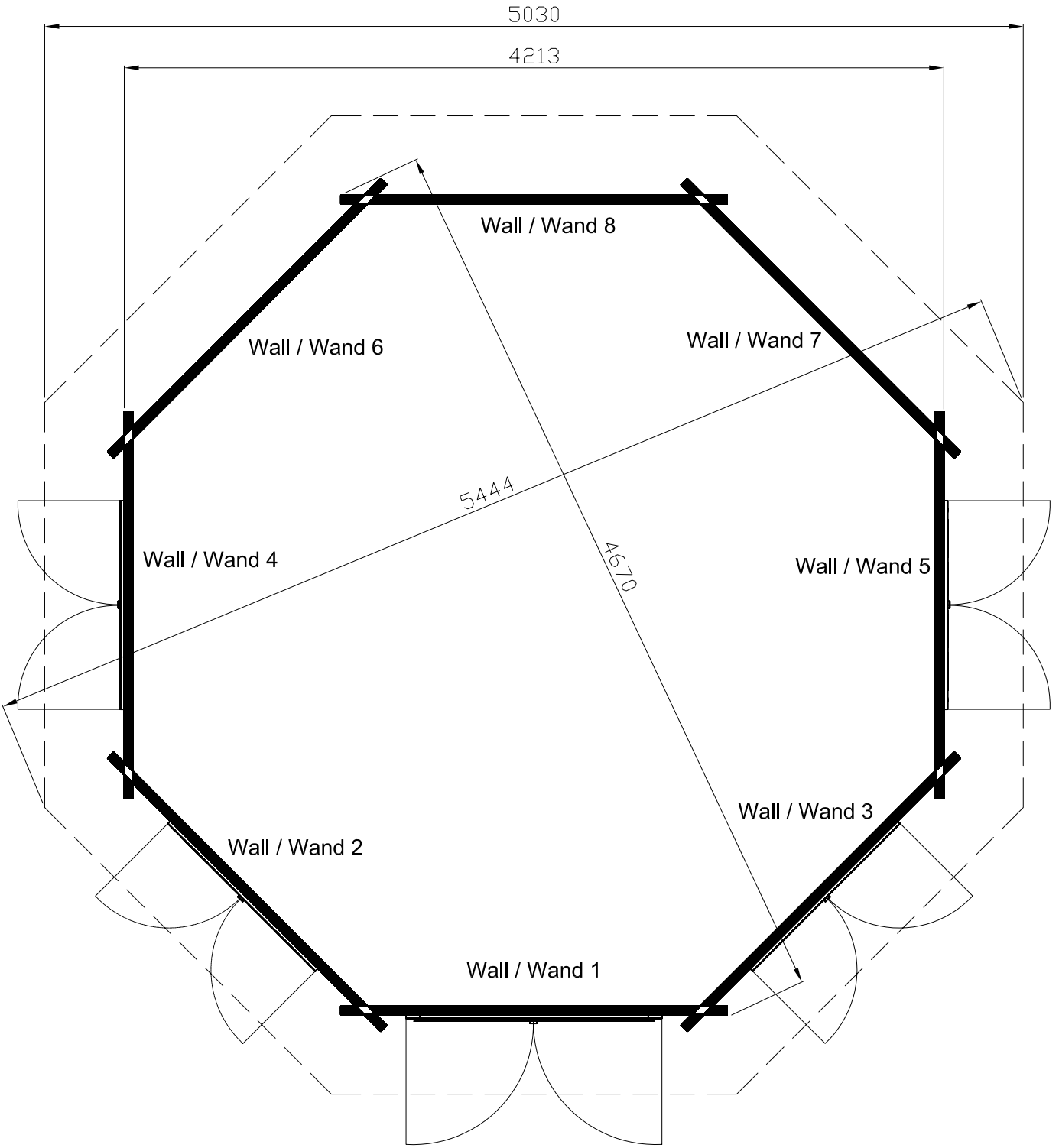

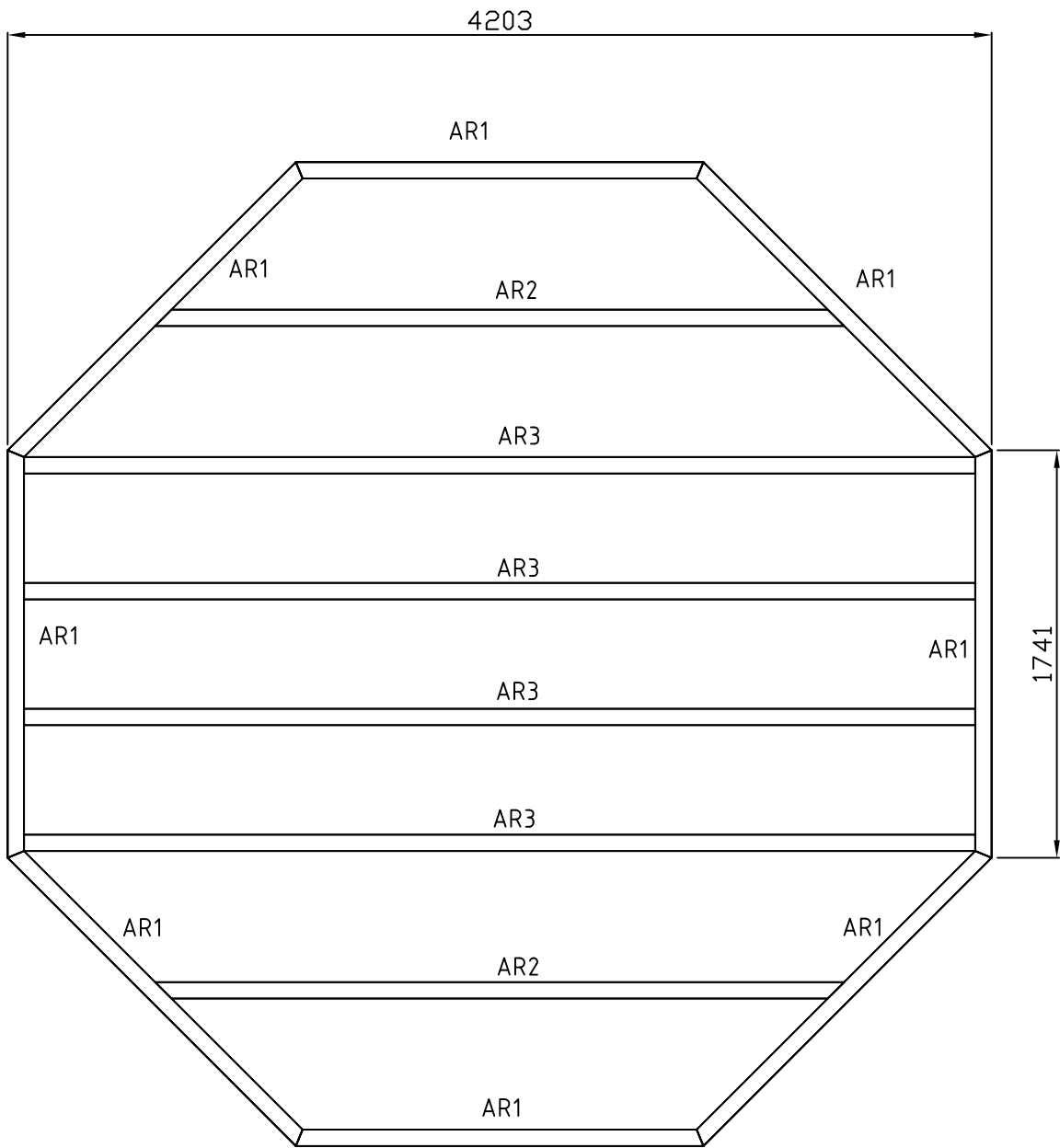

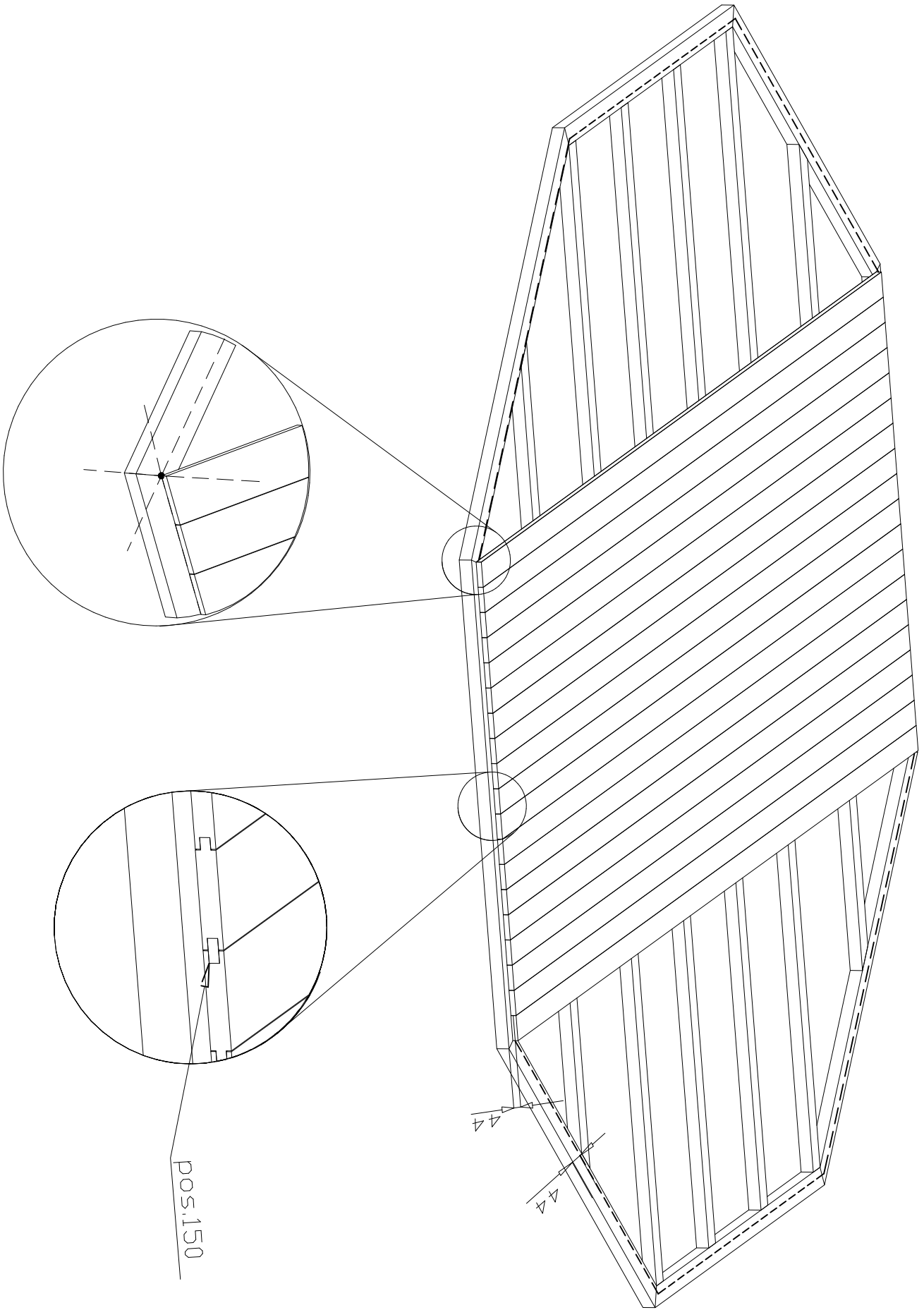

Wall / Wand 1

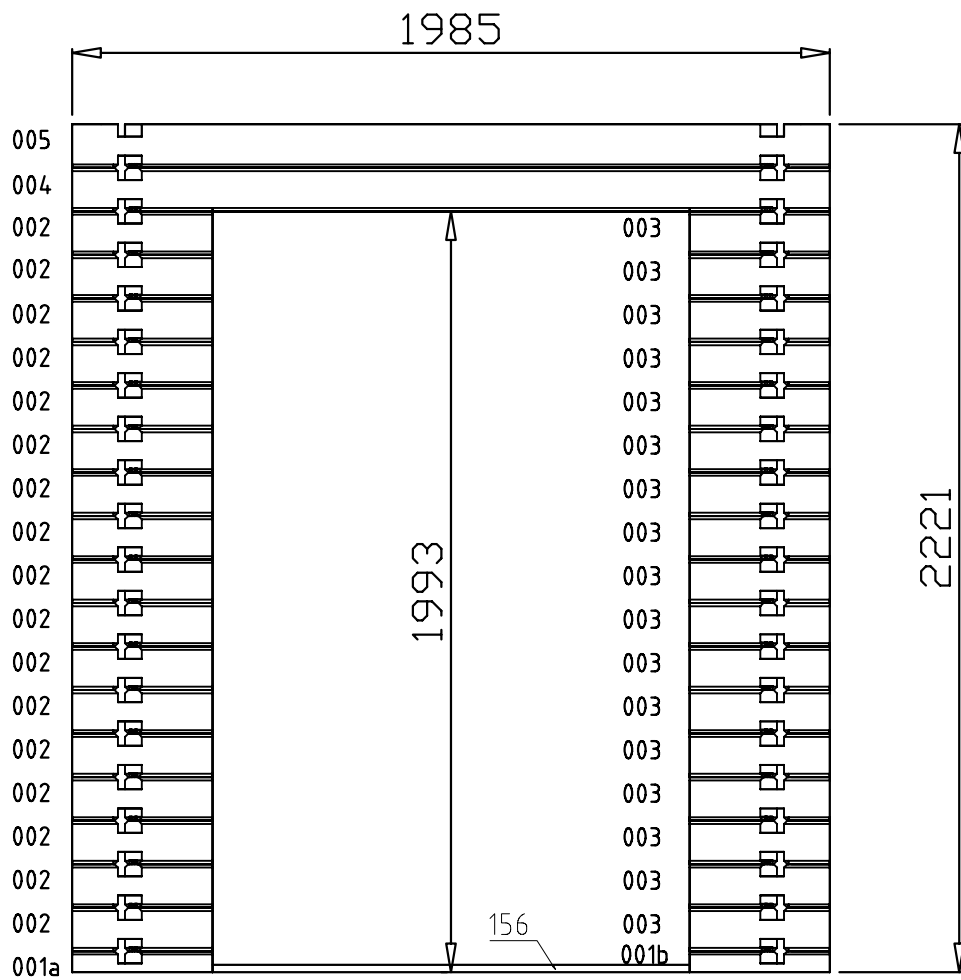

1985

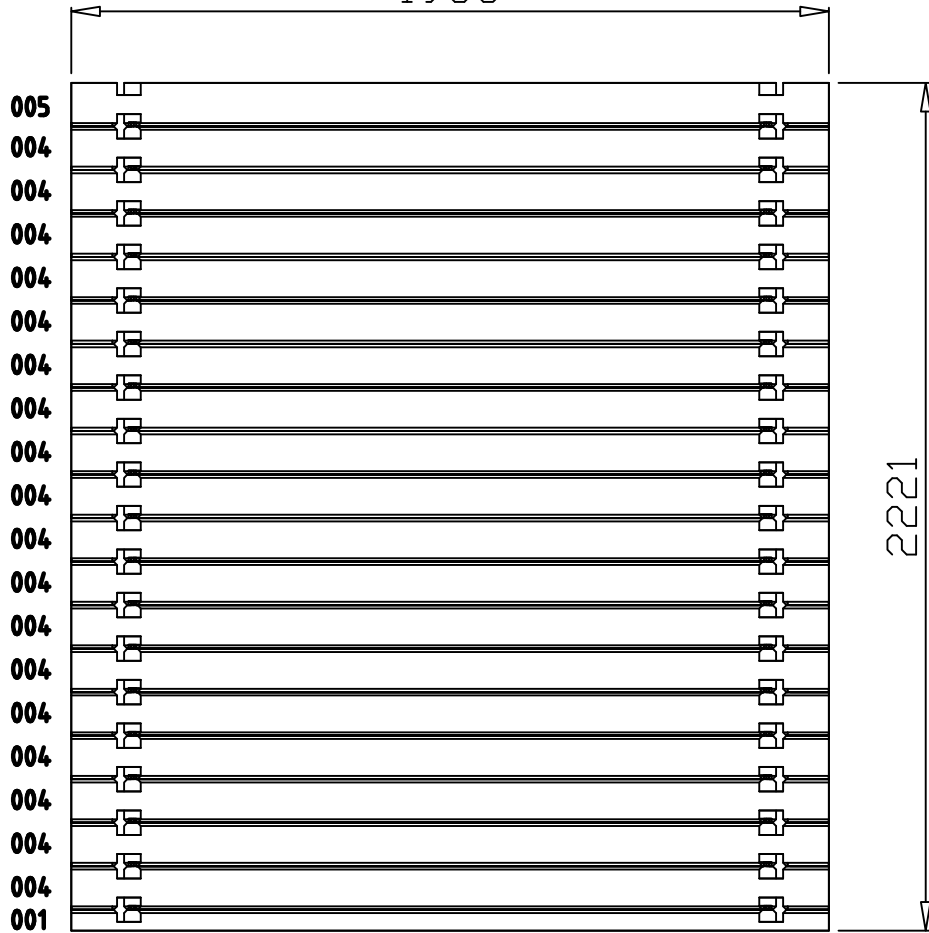

Wall / Wand 8

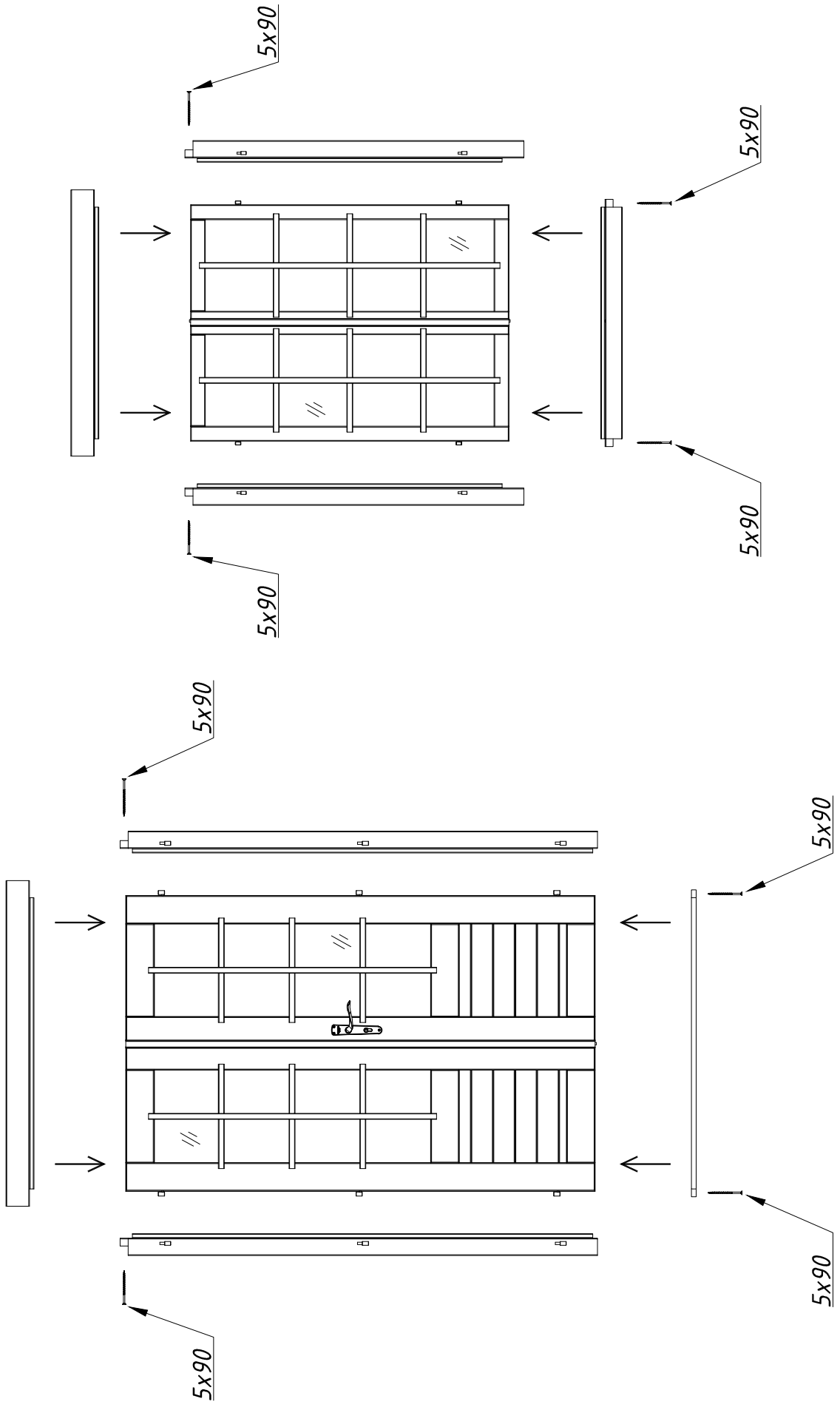

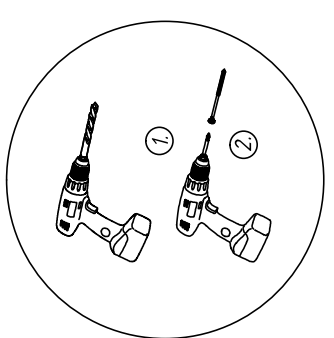
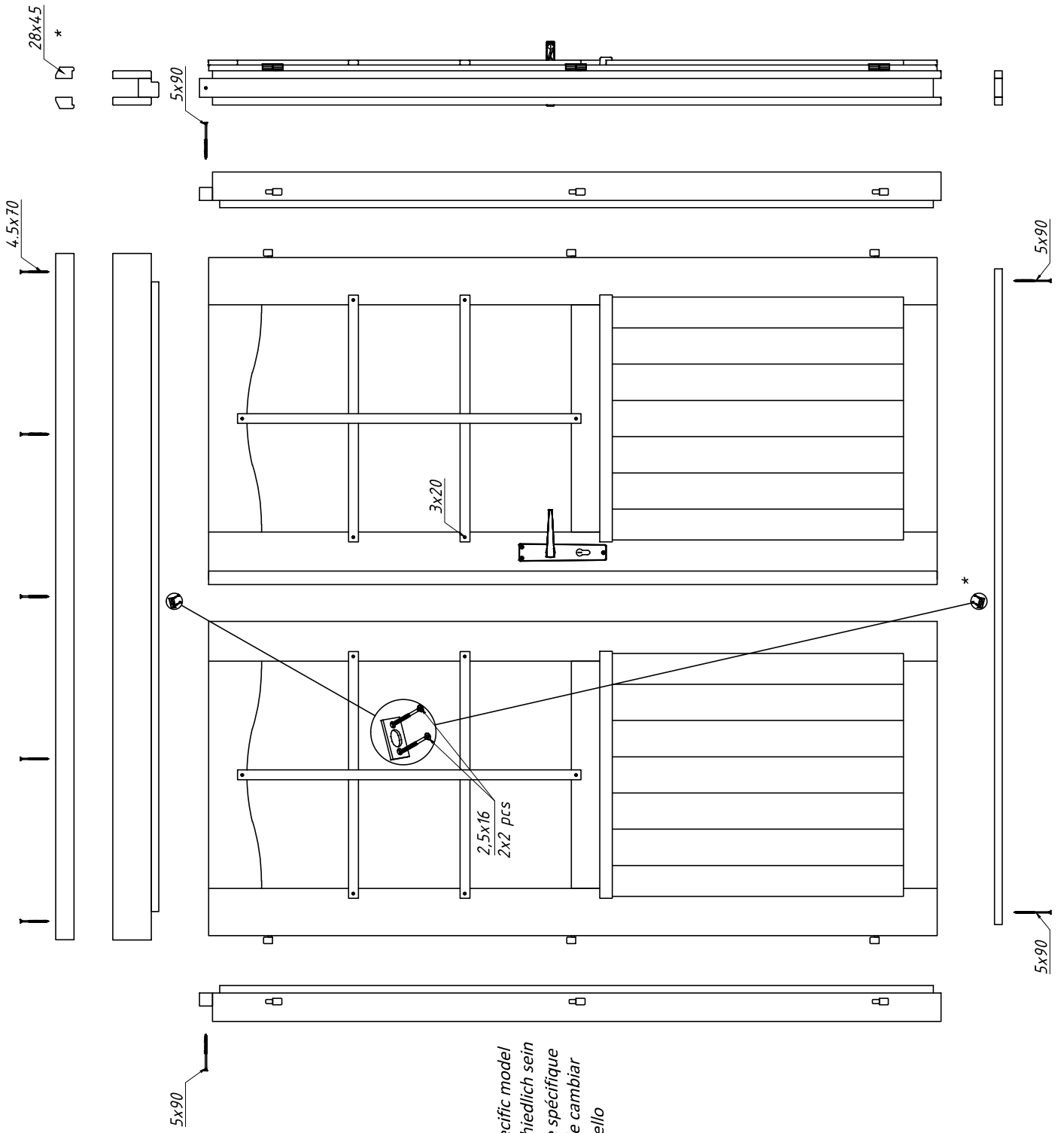

* The specification may vary depending on the specific model
 * Die Spezifikation können je nach Modell unterschiedlich sein
 * Les spécifications peuvent varier selon le modèle spécifique
 * Dependiendo del modelo, la especificación puede cambiar
 * Le specifiche possono variare a seconda del modello

1.

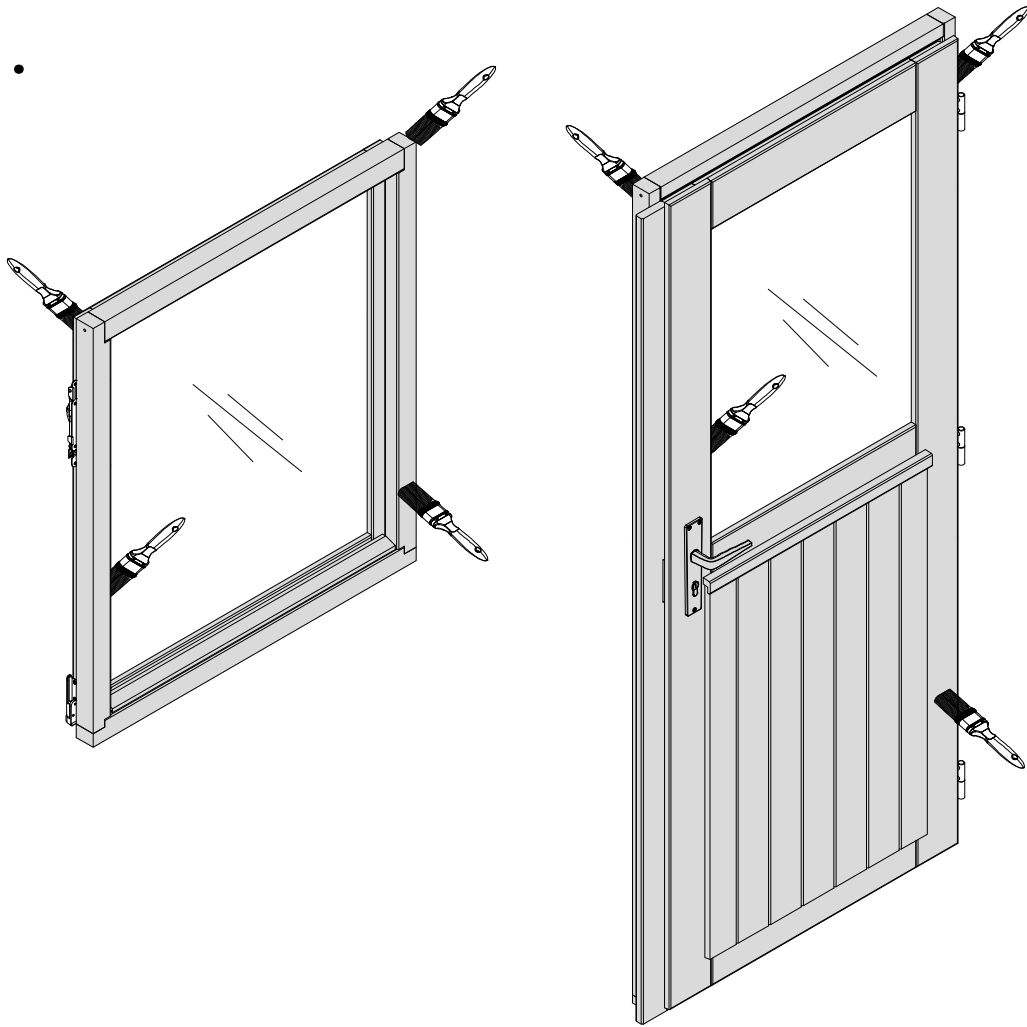

2.

